

***Thermo Top Z***  
***Supplementary Heater***

***Thermo Top E***  
***Thermo Top C***  
***Auxiliary Heater***

Type Thermo Top E - B  
Type Thermo Top Z/C - B  
Fuel

Type Thermo Top E - D  
Type Thermo Top Z/C - D  
Diesel

---

**List of Contents**

<b>1</b>	<b>Introduction</b>	
1.1	Scope and Purpose .....	101
1.2	Meaning of Warnings, Cautions, and Notes .....	101
1.3	Additional Documentation to be used .....	101
1.4	Safety Information and Regulations.....	101
	1.4.1 Legal Provisions for Installation.....	101
	1.4.2 General Safety Notes .....	102
1.5	Corrections and Improvements.....	102
<b>2</b>	<b>General Description</b>	
2.1	Combustion Air Fan Assembly .....	202
	2.1.1 Combustion Air Fan.....	202
2.2	Burner Housing.....	202
2.3	Burner Insert .....	202
2.4	Control Unit / Heat Exchanger .....	203
	2.4.1 Control Unit.....	203
	2.4.2 Temperature Sensor.....	203
	2.4.3 Overheat Protection.....	203
	2.4.4 Heat Exchanger.....	203
2.5	Circulation Pump (Thermo Top E and C only).....	203
2.6	Dosing Pump .....	203
<b>3</b>	<b>Functional Description</b>	
3.1	Functional Description Thermo Top Z (Supplementary Heater).....	301
	3.1.1 Switch On / Starting.....	301
	3.1.2 Heating Operation .....	301
	3.1.3 Switch Off / Deactivation .....	301
3.2	Functional Description Thermo Top E and C (Auxiliary Heater).....	302
	3.2.1 Switch On .....	302
	3.2.2 Heating Operation .....	302
	3.2.3 Switch Off .....	302
	3.2.4 Auxiliary Heater in Supplementary Heater Function.....	303
<b>4</b>	<b>Technical Data</b>	
4.1	Thermo Top E.....	401
4.2	Thermo Top Z/C (Heating Flow 5.0 kW).....	402
4.3	Thermo Top Z/C (Heating Flow 5.2 kW).....	403

<b>5</b>	<b>Troubleshooting</b>	
5.1	General Fault Symptoms .....	501
5.2	Error Messages during Functional Test with Diagnosis Tester Thermo Test .....	502
5.3	Malfunctions.....	503
5.3.1	Error Lockout by Malfunction of Heater .....	503
5.3.2	Error Lockout due to Low or High Voltage.....	503
5.3.3	Error Lockout Reset.....	503
<b>6</b>	<b>Functional Checkouts</b>	
6.1	General .....	601
6.2	Functional Tests in the Vehicle .....	601
6.2.1	Heating Operational Test (Thermo Top E and C).....	601
6.2.2	Timer Functional Test (Thermo Top E and C) .....	602
6.2.3	Telestart T60 Functional Test (Thermo Top C) .....	602
6.2.4	Telestart T70 Functional Test (Thermo Top C and E) .....	602
6.2.5	Functional Test with Diagnosis Tester Thermo Test .....	603
6.2.6	CO <sub>2</sub> Setting .....	604
6.3	Repair Shop Level Testing.....	604
6.3.1	Components Testing.....	604
<b>7</b>	<b>Circuit Diagrams</b>	
7.1	General .....	701
<b>8</b>	<b>Servicing</b>	
8.1	General .....	801
8.2	Work on the Heater.....	801
8.3	Work on the Vehicle.....	801
8.4	Heater Test Run.....	801
8.5	Servicing .....	801
8.6	Visual Inspections and Installation Regulations.....	801
8.6.1	Connection to Vehicle Cooling System.....	801
8.6.2	Connection to Vehicle Fuel System.....	803
8.6.3	Air Intake Muffler.....	805
8.6.4	Exhaust Line .....	805
8.7	Removal and Installation.....	806
8.7.1	Heater, Removal and Installation.....	806
8.7.2	Timer, Removal and Installation .....	806
8.8	Initial Operation.....	806

<b>9</b>	<b>Repair</b>	
9.1	General .....	901
9.1.1	Work on Components after Disassembly .....	901
9.2	Disassembly and Assembly .....	902
9.2.1	Circulation Pump, Replacement (Thermo Top E and C) .....	902
9.2.2	Combustion Air Fan, Replacement.....	903
9.2.3	Burner Insert with Glow Plug / Flame Sensor, Replacement .....	905
9.2.4	Control Unit / Heat Exchanger with Burner Housing, Replacement .....	905
<b>10</b>	<b>Packaging, Storage and Shipping</b>	
10.1	General .....	1001

**List of Figures**

501	Fault Symptoms .....	501
502	Error Messages.....	502
701	Control Unit Connector Pin Assignment (Thermo Top E and C) .....	701
702	Automatic Switching Circuit for Thermo Top E and Z/C, 12 V Timer and Telestart T60.....	702
703	Automatic Switching Circuit for Thermo Top E and Z/C, 12 V Timer .....	703
704	Automatic Switching Circuit for Thermo Top Z, 12 V .....	704
801	"Inline Integration" in the Engine Water Cooling Circuit.....	801
802	Example for Heater Installation in Passenger Vehicle .....	802
803	Fuel Supply .....	802
804	Webasto Fuel Tap.....	803
805	Pipe/Hose Connection .....	804
806	Dosing Pump, Installation Position .....	804
807	Air Intake Muffler, Installation Position.....	805
808	Exhaust Pipe Outlet, Installation Position .....	805
809	Timer, Removal and Installation .....	806
901	Replacement of Circulation Pump (Thermo Top E and C) .....	902
902	Heater Disassembly.....	904

## 1 Introduction

### 1.1 Scope and Purpose

This repair shop manual is intended to support familiarised personnel in the repair of the water heaters Thermo Top E, Thermo Top Z and Thermo Top C of the fuel and Diesel types.

As their appearance is identical or similar, the heaters are marked by type on their identification plate with "Benzin" (fuel) or "Diesel". The heaters may only be operated with the specified type of Diesel (or with fuel oil EL) and the appropriate type of electrical installation.

Heaters which have Diesel or fuel specified on their identification plate must not be operated with PME (vegetable methyl ester).

Thermo Top E and C are variants of Thermo Top Z with a circulation pump.

### 1.2 Meaning of Warnings, Cautions, and Notes

WARNINGS, CAUTIONS, and NOTES in this manual have the following meaning:

#### WARNING

This heading is used to highlight that non-compliance with instructions or procedures may cause injuries or lethal accidents to personnel.

#### CAUTION

This heading is used to highlight that non-compliance with instructions or procedures may cause damage to equipment.

#### NOTE

This heading is used to highlight and draw specific attention to information.

### 1.3 Additional Documentation to be used

This workshop manual contains all information and procedures necessary for the repair of water heaters Thermo Top E, Thermo Top Z and Thermo Top C. The use of additional documentation is normally not necessary.

Operating instructions/installation instructions and the vehicle specific installation proposal may be used as complementary information as necessary.

### 1.4 Safety Information and Regulations

The general safety regulations for the prevention of accidents and the relevant operating safety instructions have to be observed at all times. "General Safety Regulations" beyond the scope of these regulations are detailed in the following.

The specific safety regulations applicable to this manual are highlighted in the individual chapters by Warnings, Cautions, and Notes.

#### 1.4.1 Legal Provisions for Installation

Within the scope of the StVZO (Road Licensing Regulations of the Federal Republic of Germany) "Design General Approvals" laid down by the Federal Office for Motor Traffic exist for the Water Heaters Thermo Top with the following official marks of conformity:

- ~ S316 for Heater Thermo Top E-B (fuel type)
- ~ S317 for Heater Thermo Top E-D (Diesel type)
- ~ S292 for Heater Thermo Top Z/C-B (fuel type) and
- ~ S289 for Heater Thermo Top Z/C-D (Diesel type).

Installation of the heater is to be performed in accordance with the installation instructions and must be checked in case of

- a) the vehicle type inspection in accordance with § 20 StVZO
- b) the individual inspection in accordance with § 21 StVZO or
- c) the examination in accordance with § 19 StVZO performed by an officially authorised expert or examiner for road traffic, a vehicle inspector or a public servant as per section 4 of Annex VIIIb to the StVZO.

In the event of c) the installation must be certified on the acceptance certificate included in the copy of the "General Operating License" giving details about

- manufacturer
- type of vehicle and
- vehicle identification number.

This validates the "Design General Approval". The acceptance certificate must be kept with the vehicle.

**The obligation to apply for a new "Operating License" (with expertise) after heater installation does not exist, if the installation meets entirely the requirements of an installation instruction, for which a special supplement exists for the "Design General Approval". The "Design General Approval" and the "Operating License" documentation are to be kept with the vehicle.**

The heaters are cleared for heating the vehicle engine and the vehicle cabin. When using the heaters in vehicles not subject to the Road Licensing Regulations (StVZO) (e.g. ships), the applicable partially regional regulations

must be observed. The use of the heater in "vehicles for the transportation of dangerous goods" (ADR) is not permitted.

The examination is performed by presentation of the manufacturer's operating/installation instructions. The year of first operation must be durably marked by the installer on the heater identification label by removing the numerals of the years not applicable.

The heater must not be installed in the passenger or driver compartments of vehicles.

The heater may only be installed in vehicles or independent heating systems with a minimum coolant capacity of 4 litres.

When checking the cooling water level proceed in accordance with the vehicle manufacturer's instructions. The water in the heating circuit of the heater must contain at least 10 % of a quality brand anti-freeze.

Extracting combustion air from the vehicle interior is prohibited.

The exhaust line outlet is to point downwards or to the side, or in case of exhaust venting below the vehicle floor, to be located at the nearest possible location of the vehicle's or cockpit side or rear end.

Exhaust lines must be routed so that exhaust fumes are unlikely to penetrate into the vehicle's interior. The function of any part of the vehicle essential for operation must not be impaired. Accumulations of condensate in the exhaust line must be directly drained. A drain hole may be provided as required.

The openings of the combustion air inlet and the exhaust outlet must not allow a ball of 16 mm in diameter to be inserted.

Electrical lines and switching gear of the heater must be located in the vehicle so that their proper function cannot be impaired under normal operating conditions.

For the routing of fuel lines and the installation of additional fuel tanks §§ 45 and 46 of the StVZO are to be adhered to. The most important regulations are:

- fuel lines are to be designed in such a way that they remain unaffected by torsional stresses in the vehicle, engine movement, and the like. They must be protected against mechanical damage. Fuel-carrying parts are to be protected against excessive heat and are to be arranged so that any dripping or evaporating fuel can neither accumulate nor be ignited by hot components or electrical equipment.
- the heater must not be located in rooms accommodating persons.

- the heater mode of operation – at least "on" or "off" – must be clearly visible.

## 1.4.2 General Safety Notes

At filling stations and fuel depots the heater must be switched off as there is a potential danger of explosion.

Due to the danger of poisoning and suffocation the heater must not be operated, not even with timer or under remote radio control (Telestart), in enclosed areas such as garages or workshops not equipped with an exhaust venting facility.

In the vicinity of the heater a temperature of 120° C (storage temperature) must not be exceeded under any circumstances (e.g. during body paint work). Excessive temperatures may cause permanent damage to the electronics.

All fuel lines must have leak-proof connections, must show no damage and must be checked in regular intervals (at least to the same schedule as the vehicle itself). Should damage or leakage be detected, it is not permitted to continue heater operation until the damage has been rectified by an authorized Webasto repair shop.

### NOTE

Make heater inoperative by removing fuse. The fuel lines (Mecanyl hoses) must not come into direct contact with exhaust pipe and must be thermally insulated to prevent fires.

Non-compliance with the installation instructions will void the Webasto warranty. The same applies for unskilled repairs or repairs not using original spare parts. This will also void the general marks of conformity of the heater and thus the vehicle's permit of operation.

Before first operation make sure to read the heater operating instructions.

## 1.5 Corrections and Improvements

Deficiencies, improvements, or proposals for correction of this workshop manual are to be mailed to:

Webasto Thermosysteme GmbH  
Abt. Technische Dokumentation  
D-82131 Stockdorf  
Telefon: 089/85794-542  
Telefax: 089/85794-757

**2 General Description**

The water heater Thermo Top Z (supplementary heater) is intended to compensate for the shortage in heat generated by engines optimised for low fuel consumption.

The water heater Thermo Top E and C (auxiliary heater) is used to:

- heat the vehicle cabin,
- defrost the vehicle windscreens,
- preheat water-cooled vehicle engines.

The heater Thermo Top Z may be converted into an auxiliary heater using a retrofit kit.

The heater designed to the evaporator principle operates intermittently controlled by the temperature sensor.

In order to minimise the battery's workload the heater switches from full-load operation to part-load operation after reaching a water temperature of 72° C.

In this mode of operation the heater operates with extremely low noise and particularly low power and fuel consumption.

The heater consists of the combustion air fan assembly, the control unit/heat exchanger, the burner insert and the combustion chamber. The Thermo Top E and C heater has an additional circulation pump.

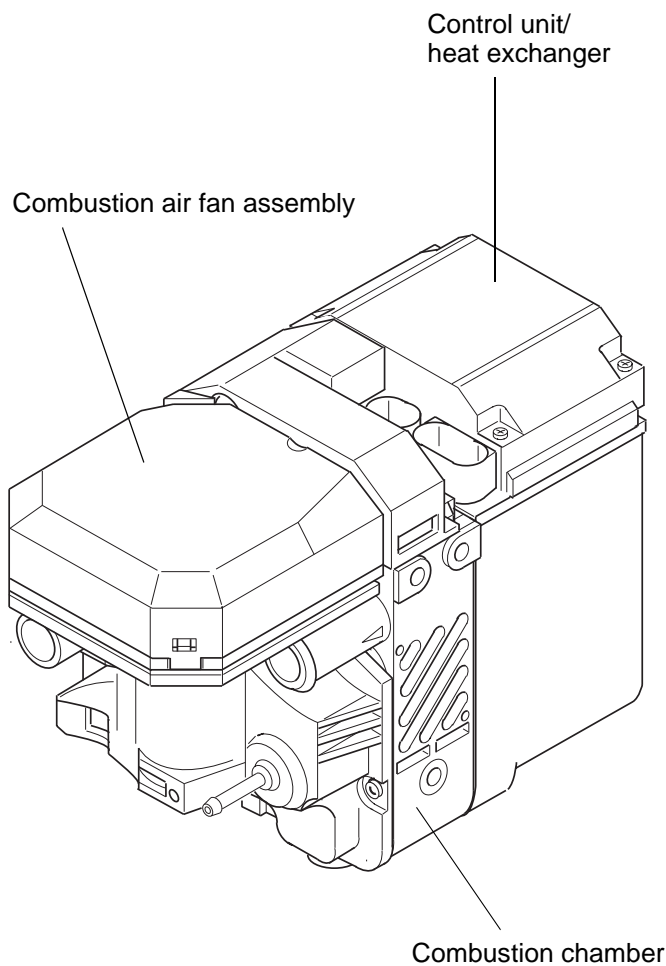

Thermo Top Z

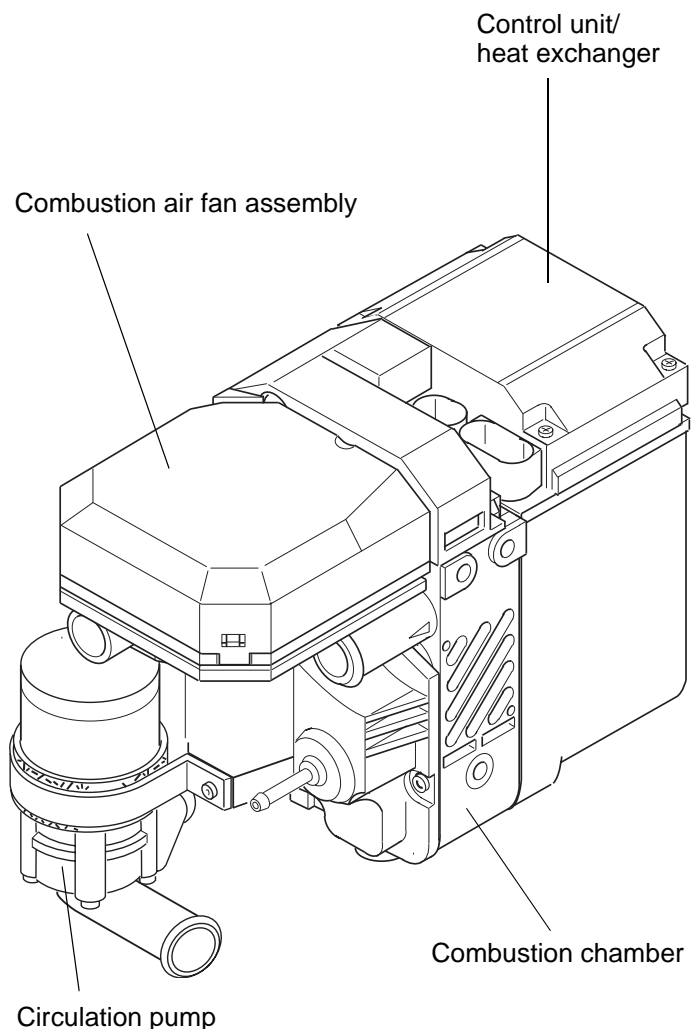

Thermo Top E and C



### 2.1 Combustion Air Fan Assembly

The combustion air fan assembly includes the

- combustion air fan
- combustion air line inlet
- fuel supply inlet.

The heater Thermo Top E and Z has the circulation pump mounted on the combustion air fan assembly.

#### 2.1.1 Combustion Air Fan

The combustion air fan delivers the air required for combustion from the combustion air inlet to the burner insert.

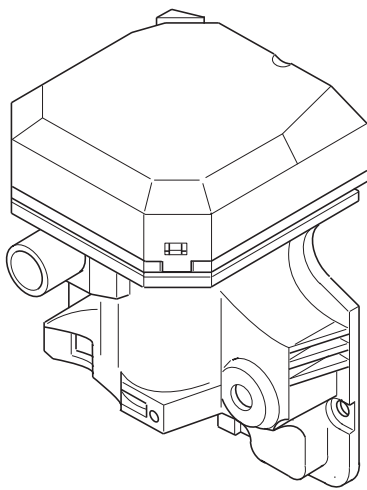

Combustion Air Fan Assembly

### 2.2 Burner Housing

The burner housing includes the

- coolant inlet
- coolant outlet
- exhaust outlet.

The burner housing accommodates the burner insert and is combined with the control unit / heat exchanger to an assembly.

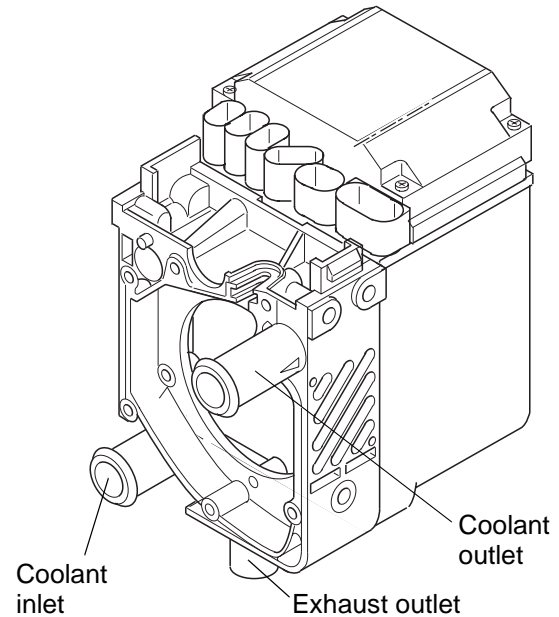

Burner Housing

### 2.3 Burner Insert

Inside the burner insert fuel is distributed across the combustion pipe fuel cross section. Combustion of the fuel/air mixture takes place within the combustion pipe to heat the heat exchanger.

The glow plug/flame sensor located in the burner insert ignites the fuel/air mixture during start of the heater. After start the glow plug / flame sensor operates in the flame sensor function. The glow plug / flame sensor designed as an electrical resistor is located in the burner insert opposite the flame side.

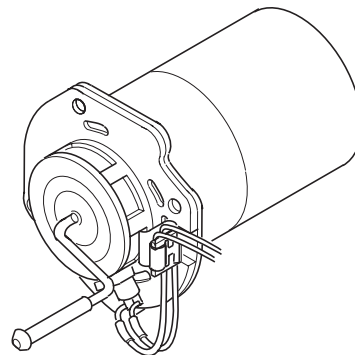

Burner Insert

**2.4 Control Unit / Heat Exchanger**

The control unit / heat exchanger includes the

- control unit
- temperature sensor
- overheat protection
- heat exchanger
- connector terminal.

**CAUTION**

The control unit / heat exchanger and the burner housing represent an assembly and must not be disassembled.

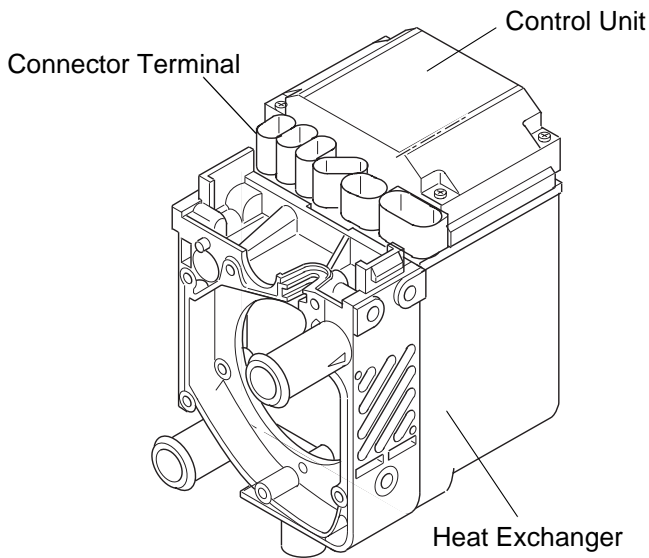

**2.4.1 Control Unit**

The control unit is the central unit and ensures control and monitoring of combustion operation.

The control unit is ventilated by means of a ventilation hose routed from the combustion air collector compartment of the burner.

**2.4.2 Temperature Sensor**

The temperature sensor senses the coolant temperature in the heat exchanger of the heater as an electrical resistance. This signal is routed to the control unit for processing.

**2.4.3 Overheat Protection**

Overheat protection, controlled by a temperature resistor, protects the heater against undue operating temperatures. Overheat protection responds at a water temperature in excess of 105° C and switches the heater off.

**2.4.4 Heat Exchanger**

The heat exchanger transfers the heat generated by combustion to the coolant circuit.

**2.5 Circulation Pump (Thermo Top E and C only)**

The circulation pump ensures circulation of the coolant within the vehicle and heater coolant circuit. The pump is activated by the control unit and is in continuous operation.

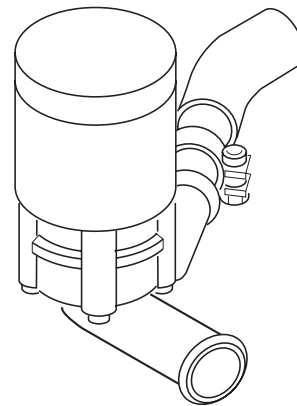

Circulation Pump

**2.6 Dosing Pump**

The dosing pump is a combined delivery, dosing and shut-off system for the fuel supply of the heater out of the vehicle fuel tank.

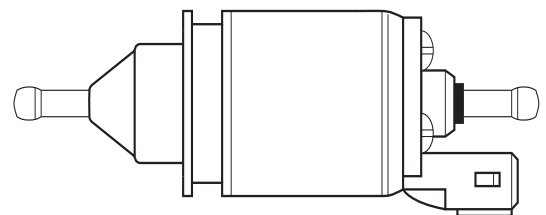

Dosing Pump DP 2 for Fuel operated Heaters

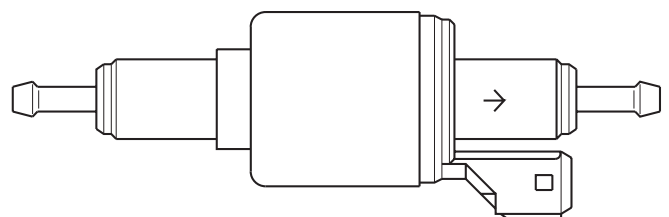

Dosing Pump DP 30.2 for Diesel operated Heaters



### 3 Functional Description

#### 3.1 Functional Description Thermo Top Z (Supplementary Heater)

##### 3.1.1 Switch On / Starting

###### *Fuel*

When starting the vehicle engine the heater goes in standby. With a water circuit temperature below 60° C and an outside temperature below 5° C (option with outside temperature sensor) the starting sequence commences. The glow plug and the combustion air fan are activated. After 30 seconds the fuel dosing pump starts operation and combustion air fan operation is suspended for 3 seconds. Subsequently the combustion air fan speed is increased in a ramp within 57 seconds to nearly full load operation.

After reaching full load fuel delivery within this period the glow plug is deactivated and the combustion air fan operation increased to full load.

During the subsequent 45 seconds as well as in normal operation the glow plug functions as flame sensor to monitor the flame condition.

After all these events the automatically controlled heating operation starts. In case of a no flame condition or a flameout, a restart is automatically initiated. If the no flame condition persists, fuel delivery is stopped and the heaters enters an error lockout with a run-down of the combustion air fan.

###### *Diesel*

When starting the vehicle engine the heater goes in standby. With a water circuit temperature below 60° C and an outside temperature below 5° C (option with outside temperature sensor) the starting sequence commences. The glow plug and the combustion air fan are activated. After 30 seconds the fuel dosing pump starts operation and combustion air fan operation is suspended for 3 seconds. Subsequently the combustion air fan speed is increased in two ramps within 56 seconds to nearly full load operation. After a stabilisation phase (constant speed) of 15 seconds the combustion air fan speed is again increased in a ramp within 50 seconds to nearly full load.

After reaching full load fuel delivery the glow plug is deactivated and the combustion air fan operation increased to full load.

During the subsequent 45 seconds as well as in normal operation the glow plug functions as flame sensor to monitor the flame condition.

After all these events the automatically controlled heating operation starts. In case of a no flame condition or a flameout, a restart is automatically initiated. If the no flame condition persists, fuel delivery is stopped and the heater enters an error lockout with a run-down of the combustion air fan.

A flameout during normal combustion operation causes an automatic restart.

##### 3.1.2 Heating Operation

###### *Fuel*

When the temperature rises to reach 72° C the heater switches to the energy saving part load operation. A rise in temperature up to 76.5° C causes the heater to enter a control idle period. This also happens when exceeding a total heating operating time of 76 minutes.

After cool-down of the coolant to 71° C the heater resumes part load operation. Another rise in temperature to 76.5° C causes the heater to enter again the control idle period. A drop in the coolant temperature during part load operation due to an increased demand in heat will cause the heater to switch to full load operation at 56° C.

###### *Diesel*

Heating operation for the Diesel type heater is identical in the sequence of events. Should the coolant temperature drop during the control idle period to but not below 71° C within 900 seconds, a subsequent drop in the coolant temperature below 71° C causes the heater to perform a regular starting sequence into full load operation.

A drop in the coolant temperature during part load operation due to an increased demand in heat will cause the heater to switch to full load operation at 65° C.

##### 3.1.3 Switch Off / Deactivation

When turning the engine off the heater is deactivated. Combustion stops and run-down commences. The combustion air fan first continues operation to cool the heater down (run-down) to be automatically switched off afterwards.

###### **NOTE**

The run-down time and the combustion air fan speed depend on the heater operating condition at the time of deactivation.

Run-down time is for:

###### *Fuel*

168 seconds when deactivated in full load operation and 157 seconds when deactivated in part load operation.

###### *Diesel*

175 seconds when deactivated in full load operation and 100 seconds when deactivated in part load operation. Dependent on the software variant implemented in the control unit there might be deviations from those run-down periods.

#### 3.2 Functional Description Thermo Top E and C (Auxiliary Heater)

##### 3.2.1 Switch On

###### *Fuel*

When operating the "instant heat" switch button the timer display shows  or when operating the switch on the Telestart transmitter the operating indicator light on the transmitter flashes. This puts the heater in standby.

The glow plug, the combustion air fan and the circulation pump are activated. After 30 seconds the fuel dosing pump starts operation and combustion air fan operation is suspended for 3 seconds.

Subsequently the combustion air fan speed is increased in a ramp within 57 seconds to nearly full load operation. After reaching full load fuel delivery within this period the glow plug is deactivated and the combustion air fan operation increased to full load.

During the subsequent 45 seconds as well as in normal operation the glow plug functions as flame sensor to monitor the flame condition.

After all these events the automatically controlled heating operation starts. In case of a no flame condition or a flameout, a restart is automatically initiated. If the no flame condition persists, fuel delivery is stopped and the heater enters an error lockout with a run-down of the combustion air fan.

###### *Diesel*

When operating the "instant heat" switch button the timer display shows  or when operating the switch on the Telestart transmitter the operating indicator light on the transmitter flashes. This puts the heater in standby.

The glow plug, the combustion air fan and the circulation pump are activated. After 30 seconds the fuel dosing pump starts operation and combustion air fan operation is suspended for 3 seconds.

Subsequently the combustion air fan speed is increased in two ramps within 56 seconds to nearly full load operation. After a stabilisation phase (constant speed) of 15 seconds the combustion air fan speed is again increased in a ramp within 50 seconds to nearly full load. After reaching full load fuel delivery the glow plug is deactivated and the combustion air fan operation increased to full load.

During the subsequent 45 seconds as well as in normal operation the glow plug functions as flame sensor to monitor the flame condition.

After all these events the automatically controlled heating operation starts. In case of a no flame condition or a flameout, a restart is automatically initiated. If the no flame condition persists, fuel delivery is stopped and the heater enters an error lockout with a run-down of the combustion air fan.

A flameout during normal combustion operation causes an automatic restart.

##### 3.2.2 Heating Operation

###### *Fuel*

When the temperature rises to reach 72° C the heater switches to the energy saving part load operation. A rise in temperature up to 76.5° C causes the heater to enter a control idle period. This also happens when exceeding a total heating operating time of 76 minutes.



The circulation pump, the vehicle's own heating air fan, and the operation indicator light remain on during control idle.

After cool-down of the coolant to 71° C the heater resumes part load operation. Another rise in temperature to 76.5° C causes the heater to enter again the control idle period. A drop in the coolant temperature during part load operation due to an increased demand in heat will cause the heater to switch to full load operation at 56° C.

###### *Diesel*

Heating operation for the Diesel type heater is identical in the sequence of events. Should the coolant temperature however not drop within 900 seconds during the control idle period to below 71° C, a subsequent drop in the coolant temperature below 71° C causes the heater to perform a regular starting sequence into full load operation.

##### 3.2.3 Switch Off

When turning the heater off by pushing the "instant heat" switch button  ( in indicator panel extinguishes) or when operating the switch on the Telestart (flashing indicator on hand-held transmitter extinguishes) the vehicle heating air fan stops.

Combustion terminates and run-down commences. The circulation pump and the combustion air fan first continue operation to cool the heater down (run-down) to be automatically switched off afterwards.

###### **NOTE**

The run-down time and the combustion air fan speed depend on the heater operating condition at the time of deactivation.

Run-down time is for:

###### *Fuel*

168 seconds when deactivated in full load operation and 157 seconds when deactivated in part load operation.

###### *Diesel*

175 seconds when deactivated in full load operation and 100 seconds when deactivated in part load operation. Dependent on the software variant implemented in the control unit there might be deviations from those run-down periods.

### **3.2.4 Auxiliary Heater in Supplementary Heater Function**

#### **3.2.4.1 Switch On**

When starting the engine the heater goes in standby (see 3.1.1).

With the temperature of the water circuit below 60° C and the outside temperature below 5° C (option with external temperature sensor) the starting procedure is initiated.

#### **NOTE**

When operating in the supplementary heater function there will be no automatic trigger of the circulation pump and the vehicle's heating air fan.

#### **3.2.4.2 Switch Off**

Turning the engine off deactivates the heater. Combustion is terminated and run-down commences. The combustion air fan however continues operation to cool the heater down (run-down) to be automatically switched off afterwards (see 3.1.3).



**4 Technical Data**

**4.1 Thermo Top E**

Where no threshold values are specified technical data in the table are understood to include standard tolerances for heater units of ± 10 % at an ambient temperature of + 20° C.

All electrical components are selected for a nominal voltage of 12 Volts.

**Propellant for Thermo Top E (Fuel):**

The proper fuel is the fuel specified by the vehicle manufacturer.

**Propellant for Thermo Top E (Diesel):**

The proper Diesel fuel is the one specified by the vehicle manufacturer. When switching to low temperature propellants the heater must be operated for at least 15 minutes to prime the fuel pipe and pump with the new type of fuel.

A persistent influence by additives is not known.

Heater	Operation	Thermo Top E - B	Thermo Top E - D	Thermo Top E - D
Mark of conformity		~ S316	~ S317	
Type		Water heater with evaporator burner		
Heating flow	Full load Part load	4.0 kW 2.5 kW		
Fuel		Fuel	Diesel	Diesel/PME*
Fuel consumption	Full load Part load	0.54 l/h 0.34 l/h	0.47 l/h 0.30 l/h	
Nominal voltage		12 V		
Operating voltage range		10.5 ... 15 V		
Nominal power consumption without circulation pump (without vehicle air fan)	Full load Part load	22 W 18 W		
Permissible ambient temperature:				
Heater:                    – operation		–40° C ... + 60° C		–20° C ... + 60° C
– storage		–40° C ... +120° C		–40° C ... +120° C
Dosing pump:           – operation		–40° C ... + 20° C		–20° C* ... + 20° C
Permissible operating overpressure (heat carrier)		0.4 ... 2.5 bar		
Heat exchanger capacity		0.15 l		
Minimum coolout circuit capacity		3.00 l		
Minimum volume flow for the heater		250 l/h		
CO <sub>2</sub> in exhaust (permissible functional range)		8 ... 12 Vol.-%		
Dimensions of heater		length 214 mm width 106 mm height 168 mm		
Weight		2.9 kg		

<b>Circulation pump</b>		<b>4847</b>
Volume flow against 0.1 bar		900 l/h
Nominal voltage		12 V
Operating voltage range		10.5 ... 15 V
Nominal power consumption		14 W
Dimensions of circulation pump		length 95 mm width 61 mm height 61 mm
Weight		0.3 kg

\*) Operation only permitted with mixture Diesel/PME with PME quantity < 50 %.



### 4.2 Thermo Top Z/C (Heating Flow 5.0 kW)

Where no threshold values are specified technical data in the table are understood to include standard tolerances for heater units of  $\pm 10\%$  at an ambient temperature of  $+20^\circ\text{C}$ .

All electrical components are selected for a nominal voltage of 12 Volts.

#### Propellant for *Thermo Top Z/C (Fuel)*:

The proper fuel is the fuel specified by the vehicle manufacturer

#### Propellant for *Thermo Top Z/C (Diesel)*:

The proper Diesel fuel is the one specified by the vehicle manufacturer. When switching to low temperature propellants the heater must be operated for at least 15 minutes to prime the fuel pipe and pump with the new type of fuel.

A persistent influence by additives is not known.

Heater	Operation	Thermo Top Z/C - B	Thermo Top Z/C - D	Thermo Top Z/C - D
Mark of conformity		~ S292	~ S289	
Type		Water heater with evaporator burner		
Heating flow	Full load Part load	5.0 kW 2.5 kW		
Fuel		Fuel	Diesel	Diesel/PME*
Fuel consumption	Full load Part load	0.67 l/h 0.34 l/h	0.59 l/h 0.30 l/h	
Nominal voltage		12 V		
Operating voltage range		10.5 ... 15 V		
Nominal power consumption without circulation pump (without vehicle air fan)	Full load Part load	26 W 18 W		
Permissible ambient temperature: Heater: – operation – storage Dosing pump: – operation		–40° C ... + 60° C –40° C ... +120° C –40° C ... + 20° C		–20° C ... + 60° C –40° C ... +120° C –20° C*... + 20° C
Permissible operating overpressure (heat carrier)		0.4 ... 2.5 bar		
Heat exchanger capacity		0.15 l		
Minimum coolout circuit capacity		4.00 l		
Minimum volume flow for the heater		250 l/h		
CO <sub>2</sub> in exhaust (permissible functional range)		8 ... 12 Vol.-%		
Dimensions of heater		length 214 mm width 106 mm height 168 mm		
Weight		2.9 kg		

<b>Circulation pump</b>		<b>4847</b>
Volume flow against 0.1 bar		900 l/h
Nominal voltage		12 V
Operating voltage range		10.5 ... 15 V
Nominal power consumption		14 W
Dimensions of circulation pump		length 95 mm width 61 mm height 61 mm
Weight		0.3 kg

\*) If viscosity of PME permits due to its natural condition.

**4.3 Thermo Top Z/C  
(Heating Flow 5.2 kW)**

Where no threshold values are specified technical data in the table are understood to include standard tolerances for heater units of ± 10 % at an ambient temperature of + 20° C.

All electrical components are selected for a nominal voltage of 12 Volts.

**Propellant for Thermo Top Z/C (Fuel):**

The proper fuel is the fuel specified by the vehicle manufacturer

**Propellant for Thermo Top Z/C (Diesel):**

The proper Diesel fuel is the one specified by the vehicle manufacturer. When switching to low temperature propellants the heater must be operated for at least 15 minutes to prime the fuel pipe and pump with the new type of fuel.

A persistent influence by additives is not known.

Heater	Operation	Thermo Top Z/C - B	Thermo Top Z/C - D	Thermo Top Z/C - D
Mark of conformity		~ S292	~ S289	
Type		Water heater with evaporator burner		
Heating flow	Full load Part load	5.2 kW 2.5 kW		
Fuel		Fuel	Diesel	Diesel/PME*
Fuel consumption	Full load Part load	0.70 l/h 0.34 l/h	0.61 l/h 0.30 l/h	
Nominal voltage		12 V		
Operating voltage range		10.5 ... 15 V		
Nominal power consumption without circulation pump (without vehicle air fan)	Full load Part load	28 W 18 W		
Permissible ambient temperature: Heater: – operation – storage Dosing pump: – operation		–40° C ... + 60° C –40° C ... +120° C –40° C ... + 20° C		–20° C ... + 60° C –40° C ... +120° C –20° C*... + 20° C
Permissible operating overpressure (heat carrier)		0.4 ... 2.5 bar		
Heat exchanger capacity		0.15 l		
Minimum coolout circuit capacity		4.00 l		
Minimum volume flow for the heater		250 l/h		
CO <sub>2</sub> in exhaust (permissible functional range)		8 ... 12 Vol.-%		
Dimensions of heater		length 214 mm width 106 mm height 168 mm		
Weight		2.9 kg		

<b>Circulation pump</b>		<b>4847</b>
Volume flow against 0.1 bar		900 l/h
Nominal voltage		12 V
Operating voltage range		10.5 ... 15 V
Nominal power consumption		14 W
Dimensions of circulation pump		length 95 mm width 61 mm height 61 mm
Weight		0.3 kg

\*) If viscosity of PME permits due to its natural condition.



## 5 Troubleshooting

### 5.1 General Fault Symptoms

The following table (Fig. 501) lists possible fault symptoms of general nature for heaters in installed condition.

**CAUTION**

Troubleshooting requires profound knowledge about components and their theory of operation and may only be performed by trained personnel.

In case of doubt functional interrelations may be derived from Sections 2 and 3.

**CAUTION**

Troubleshooting is normally limited to the isolation of defective components and provides information on defective wiring and connections. The following possible causes for trouble have not been taken into consideration and must always be excluded as a possible cause for malfunctions:

- corrosion on connectors**
- loose contacts on connectors**
- wrong crimping on connectors**
- corrosion on wiring and fuses**
- corrosion on battery terminals**

After any fault correction a functional checkout in the vehicle has to be performed (see 6.2).

Symptom	Remedy
Smell of fuel	Check heater system integration in vehicle's fuel system. Check fuel lines for leakage, kinks or obstructions. If o.k. there is a heater internal leak. Remove heater and perform troubleshooting on repair shop level.
Heater does not achieve full load operation	Remove heater and perform troubleshooting on repair shop level.
Continuous white smoke during combustion operation	Remove heater and perform troubleshooting on repair shop level.
Heater cannot be switched off	Perform functional test of Timer (see 6.2.2) or of Telestart device (see 6.2.3). Replace or repair defective component.
Loss of coolant (dripping); heater develops smoke during combustion operation; smell of exhaust fumes extremely sweet	Inspect coolant hoses for leakage, kinks, loose hose clamps, etc. If o.k. there is a heater internal leak. Remove heater and perform troubleshooting on repair shop level.
Loss of fuel (dripping)	Check heater system integration in vehicle's fuel system. Check fuel line connections for leakage. If o.k. there is a heater internal leak. Remove heater and perform troubleshooting on repair shop level.

Fig. 501 Fault Symptoms

## 5.2 Error Messages during Functional Test with Diagnosis Tester Thermo Test

### NOTE

The following table (Fig. 502) lists possible error messages during the functional test with the diagnosis tester and their probable cause.

Error Message	Probable Cause
Control unit defective	<ul style="list-style-type: none"> <li>Faulty electronics</li> <li>EOL programming error</li> </ul>
Flame-out 1	Flame-out during operation and no flame-up after a new attempt to start <ul style="list-style-type: none"> <li>Wrong integration in fuel system (e.g. fuel supply confused with return)</li> <li>Fuel tapping dependent on fuel level</li> <li>Pressure in fuel system too low</li> <li>Check valve in fuel system</li> <li>Leak in fuel line connections</li> <li>Degassing fuel lines (routed in environment too hot)</li> <li>Installation orientation of dosing pump</li> <li>Combustion air intake not as specified</li> <li>Exhaust system not as specified</li> <li>Burner defective</li> </ul>
Flame-out 2	Several flame-outs during operation <ul style="list-style-type: none"> <li>Wrong integration in fuel system (e.g. fuel supply confused with return)</li> <li>Fuel tapping dependent on fuel level</li> <li>Pressure in fuel system too low</li> <li>Check valve in fuel system</li> <li>Leak in fuel line connections</li> <li>Degassing fuel lines (routed in environment too hot)</li> <li>Installation orientation of dosing pump</li> <li>Combustion air intake not as specified</li> <li>Exhaust system not as specified</li> <li>Burner defective</li> </ul>
Voltage too high	<ul style="list-style-type: none"> <li>Vehicle battery charger probably defective</li> </ul>
Voltage too low	<ul style="list-style-type: none"> <li>Battery discharged or defective</li> <li>High transition resistance in the power supply lines (plus and minus)</li> </ul>
Flame before combustion operation (not applicable for Thermo Top Z)	<ul style="list-style-type: none"> <li>Glow plug / flame sensor defective</li> </ul>
Overheating	<ul style="list-style-type: none"> <li>Coolant level too low</li> <li>Heater has not been bled</li> <li>No circulation</li> </ul>
Dosing pump short circuit	<ul style="list-style-type: none"> <li>Ground short in power supply line to dosing pump</li> </ul>
Dosing pump open circuit	<ul style="list-style-type: none"> <li>Open line to dosing pump</li> <li>Short circuit to plus of power supply</li> </ul>
Burner motor short circuit	<i>Thermo Top Z:</i> <ul style="list-style-type: none"> <li>Switched line short circuit to plus of power supply</li> <li>Overload or short circuit of burner motor</li> </ul> <i>Thermo Top E und C:</i> <ul style="list-style-type: none"> <li>Ground short in power supply line to burner motor</li> </ul>
Burner motor open circuit	<ul style="list-style-type: none"> <li>Open line to burner motor</li> <li>Short circuit to plus of power supply</li> </ul>

Fig. 502 Error Messages (Sheet 1 of 2)

Glow plug short circuit	<p><i>Thermo Top Z:</i></p> <ul style="list-style-type: none"> <li>• Switched line short circuit to plus of power supply</li> <li>• Overload or short circuit of glow plug</li> </ul> <p><i>Thermo Top E und C:</i></p> <ul style="list-style-type: none"> <li>• Ground short in power supply line to glow plug</li> </ul>
Glow plug open circuit	<ul style="list-style-type: none"> <li>• Open line to glow plug / flame sensor</li> <li>• Short circuit to plus of power supply</li> <li>• Rise in coolant temperature within 9 min after start is &lt; 3 K (<i>Thermo Top C only</i>)</li> </ul>
Water pump short circuit	<p><i>Thermo Top Z:</i></p> <ul style="list-style-type: none"> <li>• Switched line short circuit to plus of power supply</li> <li>• Overload or short circuit of circulation pump</li> </ul> <p><i>Thermo Top E und C:</i></p> <ul style="list-style-type: none"> <li>• Ground short in power supply line to circulation pump</li> <li>• Overload</li> </ul>
Water pump open circuit	<ul style="list-style-type: none"> <li>• Open line to circulation pump</li> <li>• Short circuit to plus of power supply</li> </ul>
Fan short circuit	<ul style="list-style-type: none"> <li>• Line to fan relay shorted against ground</li> <li>• Overload of output to fan trigger ( I &gt; 500 mA)</li> </ul>

Fig. 502 Error Messages (Sheet 2 of 2)

### 5.3 Malfunctions

#### 5.3.1 Error Lockout by Malfunction of Heater

In case of a "no flame-up" condition fuel is delivered for a maximum of 180 seconds.

In the event of overheating (temperature limiter responds) fuel delivery is stopped immediately.

In all cases of malfunction (except for a defect on the combustion air fan) there will be an error lockout with a subsequent run-down. Dependent on the software variant implemented there might be deviations from the run-down times specified.

**NOTE**

An error lockout due to overheating does not display an indication.

#### 5.3.2 Error Lockout due to Low or High Voltage

A low voltage level of  $9.8 \pm 0.3$  V (measured at the wiring harness input) over a period of 20 seconds will cause an error lockout with a run-down of 120 seconds.

A high voltage level of  $15.5 \pm 0.5$  V (measured at the heater) over a period of more than 6 seconds will also cause an error lockout with a run-down of 120 seconds.

#### 5.3.3 Error Lockout Reset

**NOTE**

Before attempting an error lockout reset check fuse F1 in Webasto flat fuse holder. A 15 A fuse must be replaced with a 20 A fuse.

If the heater nevertheless fails to switch on, reset error lockout according to 5.3.3.4.

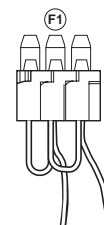

##### 5.3.3.1 Error Lockout Reset Thermo Top E and C with "Timer"

Eliminate cause of trouble.

Switch off heater using the instant heat switch on the timer and switch on again. If heater fails to switch on, perform error lockout reset according to 5.3.3.4.

An error lockout due to overheating does not have an indication.

The fuse is not blown in case of overheating.

The error lockout may be cleared by disconnection of the power supply of the control unit.

Perform error lockout reset according to 5.3.3.4.

5.3.3.2 Error Lockout Reset Thermo Top E and C with "Telestart"

Eliminate cause of trouble.  
Switch off heater using the instant heat switch on the timer or the Telestart hand transmitter and switch on again. If heater fails to switch on, perform error lockout reset according to 5.3.3.4.

An error lockout due to overheating does not have an indication.  
The fuse is not blown in case of overheating.  
The error lockout may be cleared by disconnection of the power supply of the control unit.  
Perform error lockout reset according to 5.3.3.4.

5.3.3.3 Error Lockout Reset Thermo Top Z

In case of a malfunction the control unit enters an error lockout.  
The error lockout may only be cleared by disconnection of the power supply of the control unit (e.g. by removing fuse F1 (20 A) for at least 30 seconds).

**NOTE**

The fuse must be removed within 30 seconds

- after starting the engine
- after application of 12 Volts to connector X14, contact 3

If the supplementary heater nevertheless fails to start, perform error lockout reset according to 5.3.3.4.

5.3.3.4 Error Lockout Reset after Overheating or after Three Error Lockouts

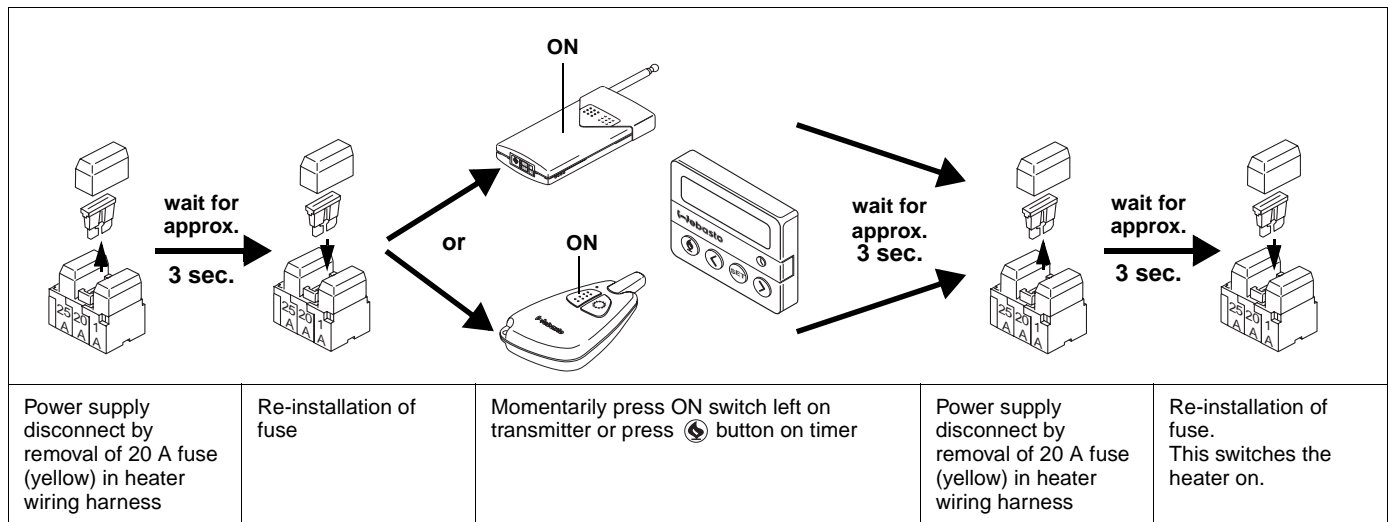

## 6 Functional Checkouts

### 6.1 General

This section describes the tests on the heater and its components in installed and removed condition as well as the test of the Timer and the Telestart T60/T70 to prove serviceability.

#### WARNING

The heater must not be operated in enclosed areas like garages or workshops not provided with exhaust ventilation facilities.

### 6.2 Functional Tests in the Vehicle

#### 6.2.1 Heating Operational Test (Thermo Top E and C)

1. Ensure that fan switch is set to the lowest stage or the stage recommended in the operating instructions.
2. Ensure that the air intake is free from foreign matter (snow, leaves etc.) and that the pollen or dust filters (if applicable) are unobstructed.
3. Ensure that that the vehicle coolant circuit and fuel system have been thoroughly bled in accordance with manufacturer's instructions.

#### NOTE

Take the time of the following functions with a stop watch or any other suitable means. The exact times for the heaters, Diesel and fuel version, are described in Section 3.

4. Switch heater on using Timer or Telestart.
  - Activation of heater causes circulation pump and combustion air fan to operate. Operating noise is audible. Vehicle heating air fan operates after coolant has reached a temperature of 30° C.
  - After approx. 130 seconds the heater starts to operate which can be verified by exhaust emissions from the exhaust muffler or exhaust pipe.
5. Allow heater to continue operation. Check heating efficiency at air exit of vehicle heating air fan.

#### NOTE

Heating efficiency depends on several factors: for assessment use outside temperature, type of vehicle, engine temperature or type of heater integration in the vehicle's cooling system, the quantity of the coolant to be heated and the time passed since heater start.

#### NOTE

Take the time of the following functions with a stop watch or any other suitable means.

6. Switch heater off using Timer or Telestart.
  - Switch off causes a run-down of approx. 110 seconds out of part load operation or of 175 seconds out of full load. Verification by stoppage of exhaust emissions and audible continuation of circulation pump operation.
  - After run-down the heater will be completely deactivated (with ignition off).



6.2.2 Timer Functional Test (Thermo Top E and C)

6.2.2.1 Voltage Check

1. Remove cover using a small screw driver.
2. Loosen screw.
3. Disconnect plug from clock.
4. Measure voltage between "+" and "-" (see figure). Voltage indicated is according to voltage of vehicle battery, approx. 12 V.

**NOTE**

In case no voltage is indicated check or replace fuse F2 and/or timer wiring.

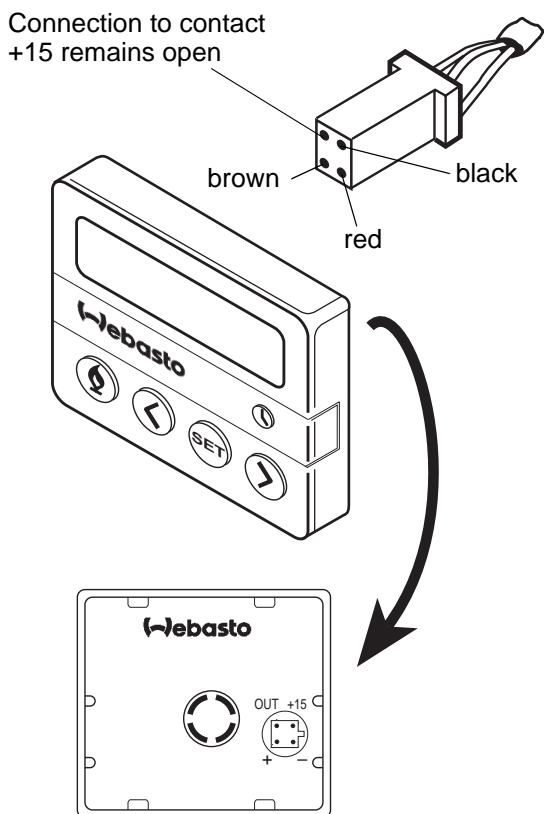

6.2.2.2 Switch On Signal Test

1. Operate "ON" button and check voltage between "-" and "OUT". Voltage is approx. 7 V with the timer connected to the control unit or 12 V with the output not connected.
2. Operate "ON" button again and check voltage between "-" and "OUT". Voltage is 0 V.

6.2.3 Telestart T60 Functional Test (Thermo Top C)

6.2.3.1 Transmitter Check

1. Operate switch on transmitter. Ensure operating indicator light (green or red LED) flashes. If LED is not flashing, batteries are too cold or too weak.
2. Using switch on transmitter switch Telestart off.

6.2.4 Telestart T70 Functional Test (Thermo Top C and E)

6.2.4.1 Batteries Check

1. Operate ON or OFF switch.

Batteries	LED	Actions
serviceable	illuminates after 1 second for approx. 0.5 seconds	
weak	flashes in orange after 1 second for 3 seconds	<ul style="list-style-type: none"> <li>- warm up batteries to above 0° C</li> <li>- replace batteries as soon as possible</li> </ul>
discharged	illuminates in orange after 1 second for 5 seconds	<ul style="list-style-type: none"> <li>- warm up batteries to above 0° C</li> <li>- replace batteries</li> </ul>

**6.2.5 Functional Test with Diagnosis Tester Thermo Test**

**NOTE**

- For operation of diagnosis tester refer to operating instructions.
- If error messages are displayed during functional testing, perform troubleshooting according to Section 5.

**CAUTION**

When connecting diagnosis tester the heater must be in switched off condition.

1. Connect screw coupling of adapter wiring harness to diagnosis tester.
2. Connect plug (yellow wire) to diagnosis connector in vehicle (connector with yellow wire).

3. Connect red battery terminal clamp to battery plus and black battery terminal clamp to battery minus of vehicle.

**NOTE**

After connection of diagnosis tester the following text is indicated alternately:

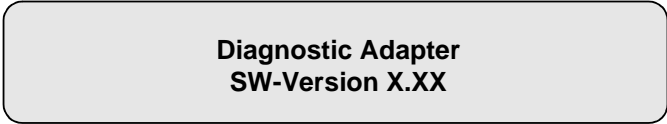

By pressing any key the equipment select menu is called up.

Working Step	Result	
	Indication	Heater
Press any key	Equipment selection	
By pressing left key select heater and language	<ul style="list-style-type: none"> <li>• Thermo Top</li> <li>• Thermo Top E</li> <li>• Thermo Top Z/C</li> <li>• Language</li> </ul>	
Acknowledge Thermo Top E or Z/C selection by pressing "OK" key	Main menu	
By pressing left key select desired function	<ul style="list-style-type: none"> <li>• Read error</li> <li>• Delete error</li> <li>• Components test</li> <li>• Automatic test</li> <li>• CO<sub>2</sub> setting</li> <li>• Equipment selection</li> </ul>	
Acknowledge selected function with "OK" key	Dependent on selected function	
Selection "Read error"	Error indication: <ul style="list-style-type: none"> <li>• maximum of 3 errors or no error</li> <li>• return</li> </ul>	
<b>NOTE</b> Record error!		
Selection "Delete error"	<ul style="list-style-type: none"> <li>• Error deleted</li> <li>• return</li> </ul>	
Selection "Components test"	<ul style="list-style-type: none"> <li>• Dosing pump on</li> <li>• Burner motor on</li> <li>• Glow plug / flame sensor on</li> <li>• Circulation pump on</li> <li>• Fan relay on</li> <li>• Cancel</li> </ul>	Dosing pump cycles Burner motor runs Glow plug / flame sensor on Circulation pump runs Fan runs
Selection "Automatic test"	<ul style="list-style-type: none"> <li>• Indication of component triggered or</li> <li>• Indication of an error</li> </ul>	Components are triggered as indicated

4. Select main menu "Equipment selection" and disconnect diagnosis tester from battery and from diagnosis connector.

6.2.6 CO<sub>2</sub> Setting**NOTE**

The CO<sub>2</sub> setting is performed with the diagnosis tester Thermo Test. For operation of diagnosis tester refer to operating instructions.

**CAUTION**

For starting heater diagnostic line must be disconnected. Connection of diagnosis tester with heater on and operating at full load (approx. 5 min after switch on). Change of CO<sub>2</sub> value in increments by pressing OK key. For settings refer to the following table:

Nominal contents of CO <sub>2</sub> in exhaust at full load operation [Vol.-%]						
Geographic altitude above sea level [m]	Air temperature [°C]					
	-20		0		20	
	Fuel	Diesel	Fuel	Diesel	Fuel	Diesel
1500	10.2	11.3	10.4	11.5	10.6	11.7
1000	9.6	10.6	9.7	10.8	9.9	11.0
500	9.0	9.9	9.1	10.1	9.3	10.3
250	8.7	9.6	8.8	9.8	9.0	10.0
0	8.4	9.3	8.6	9.5	8.8	9.7

- Switch on heater and allow to operate for approx. 5 min.
- Connect screw coupling of adapter wiring harness to diagnosis tester.
- Connect plug (yellow wire) to diagnosis connector in vehicle (connector with yellow wire).
- Connect red battery terminal clamp to battery plus and black battery terminal clamp to battery minus of vehicle.
- Switch on exhaust meter.

**NOTE**

After connection of diagnosis tester the following text is indicated alternately:

**Diagnostic Adapter  
SW-Version X.XX**

**Webasto  
Thermosysteme**

By pressing any key the equipment select menu is called up.

- Press any key.
- Select heater.
- In main menu select "CO<sub>2</sub> setting".

- Select submenu "Decrease CO<sub>2</sub>" or "Increase CO<sub>2</sub>". By pressing OK key repeatedly CO<sub>2</sub> value changes in increments. The cursor remains positioned on the selected function.

**NOTE**

By selection of "Initial value" and pressing of the OK key, the CO<sub>2</sub> value stored automatically during start of the CO<sub>2</sub> setting may be restored.

By selection of "Store/return" and pressing of the OK key, the last setting becomes the default and the main menu is called up.

- Select main menu item "Equipment selection" and disconnect diagnosis tester from battery and from diagnosis connection.
- Switch off heater.

## 6.3 Repair Shop Level Testing

## 6.3.1 Components Testing

## 6.3.1.1 Glow Plug / Flame Sensor Resistance Check

When testing the glow plug / flame sensor with a digital multimeter, the following readings should be obtained:

Resistance at 25° C: 0.3 ... 0.6 Ω  
Test current: < 5 mA

## 7 Circuit Diagrams

### 7.1 General

The connector pin assignment of control unit Thermo Top E and Z/C is shown in Fig. 701.

The circuit diagrams (Fig. 702 and 703) show the electrical circuit of the heater in combination with Timer and Telestart T60.

The circuit diagram (Fig. 704) shows the electrical circuit of Thermo Top Z.

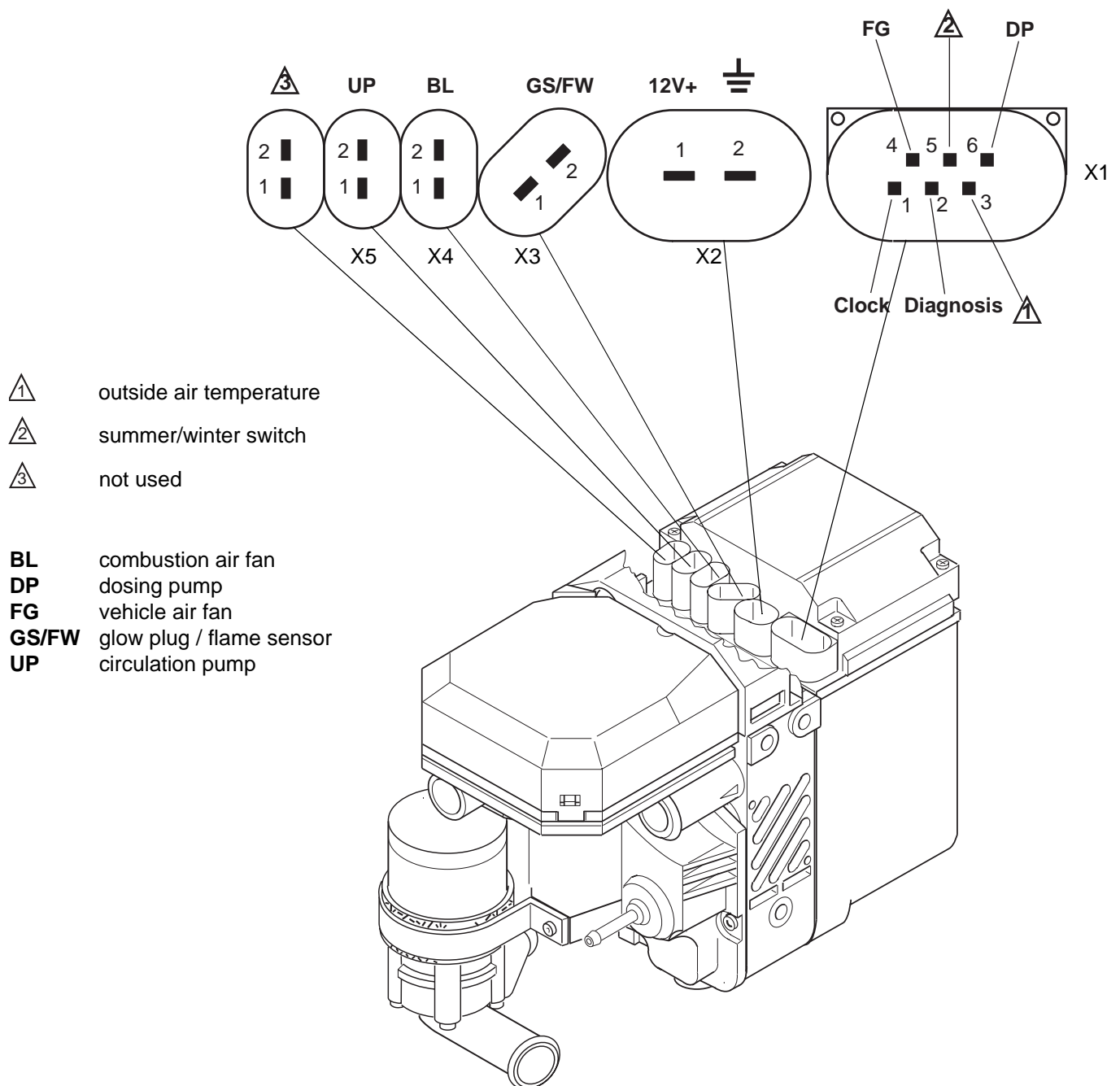
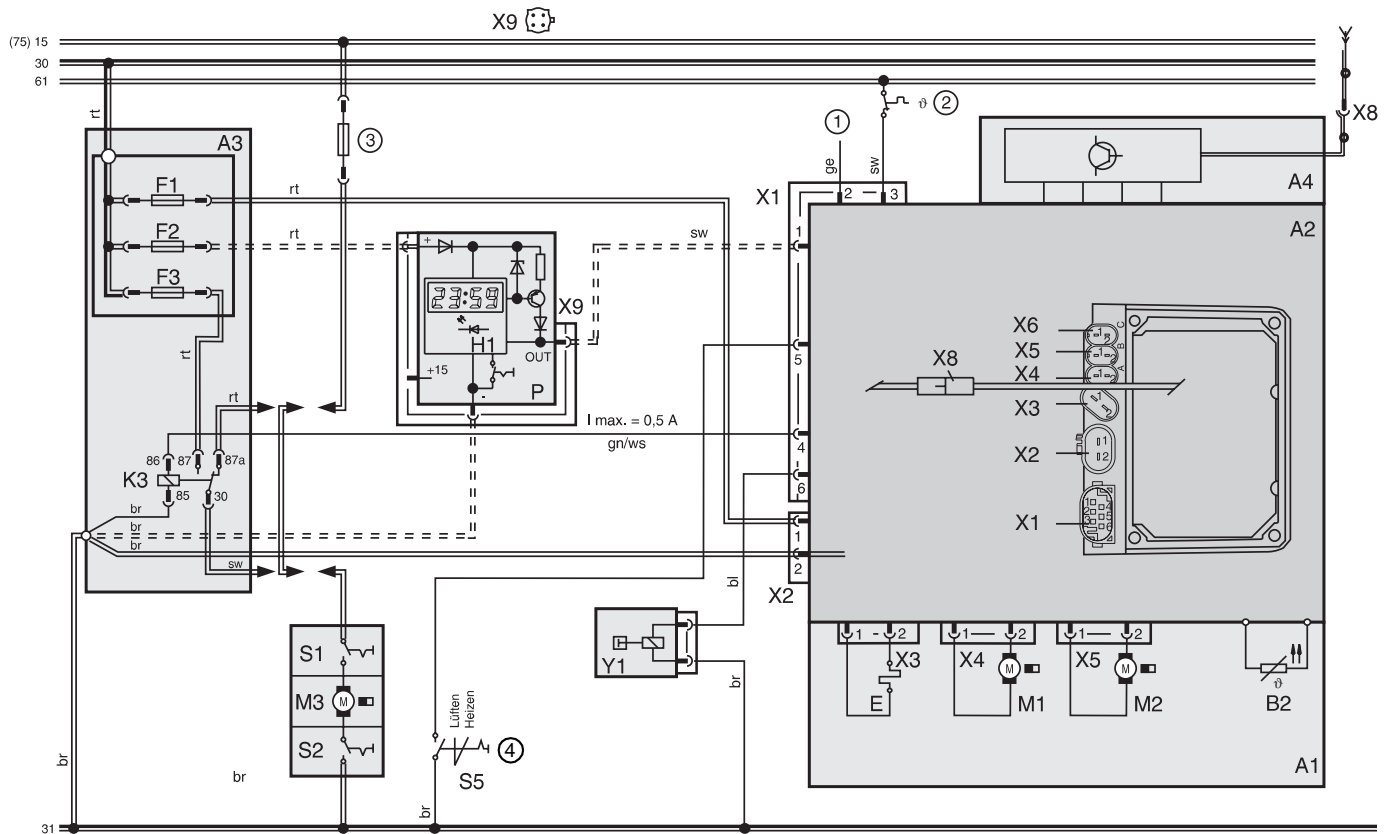

Fig. 701 Control Unit Connector Pin Assignment (Thermo Top E and C)



Item	Nomenclature	Remark
A1	Heater	Thermo Top E or Z/C
A2	Control unit	
A3	Connector box	
A4	Telestart receiver	T60
B2	Temperature sensor	
E	Glow plug / flame sensor	
F1	Fuse 15 A	Flat fuse SAE J 1284
F2	Fuse 1 A	Flat fuse SAE J 1284
F3	Fuse 25 A	Flat fuse SAE J 1284
H1	LED (in item P)	operating indicator light
K3	Relay (in item A3)	vehicle air fan
M1	Motor	combustion air fan
M2	Motor	circulation pump
M3	Motor	vehicle air fan
P	Timer, digital	for timer operation
S1	Switch for vehicle air fan	depending on vehicle S1 or S2
S2	Switch for vehicle air fan	depending on vehicle S1 or S2
S5	Switch	summer/winter switch
X1	Connection, 6-pole	
X2	Connection, 2-pole	water repellent
X3	Connection, 2-pole	water repellent
X4	Connection, 2-pole	water repellent
X5	Connection, 2-pole	water repellent
X6	Connection, 2-pole	water repellent
X8	Connection, 2-pole	HF, coaxial
X9	Connection, 4-pole	
Y1	Dosing pump	

Wire Gauges		
	< 7.5 m	7.5 - 15 m
⋯⋯⋯⋯	0,5 mm <sup>2</sup>	0,75 mm <sup>2</sup>
— — — —	0,75 mm <sup>2</sup>	1,5 mm <sup>2</sup>
— — — —	1,5 mm <sup>2</sup>	2,5 mm <sup>2</sup>
— — — —	2,5 mm <sup>2</sup>	4,0 mm <sup>2</sup>
— — — —	4,0 mm <sup>2</sup>	6,0 mm <sup>2</sup>

Wire Colours	
bl	blue
br	brown
ge	yellow
gn	green
gr	grey
or	orange
rt	red
sw	black
vi	violet
ws	white

Legend for circuit diagrams

- ① Diagnosis
- ② Outside air temperature
- ③ Vehicle heating air fan fuse provided in vehicle
- ④ Option

Fig. 702 Automatic Switching Circuit for Thermo Top E and Z/C, 12 V Timer and Telestart T60

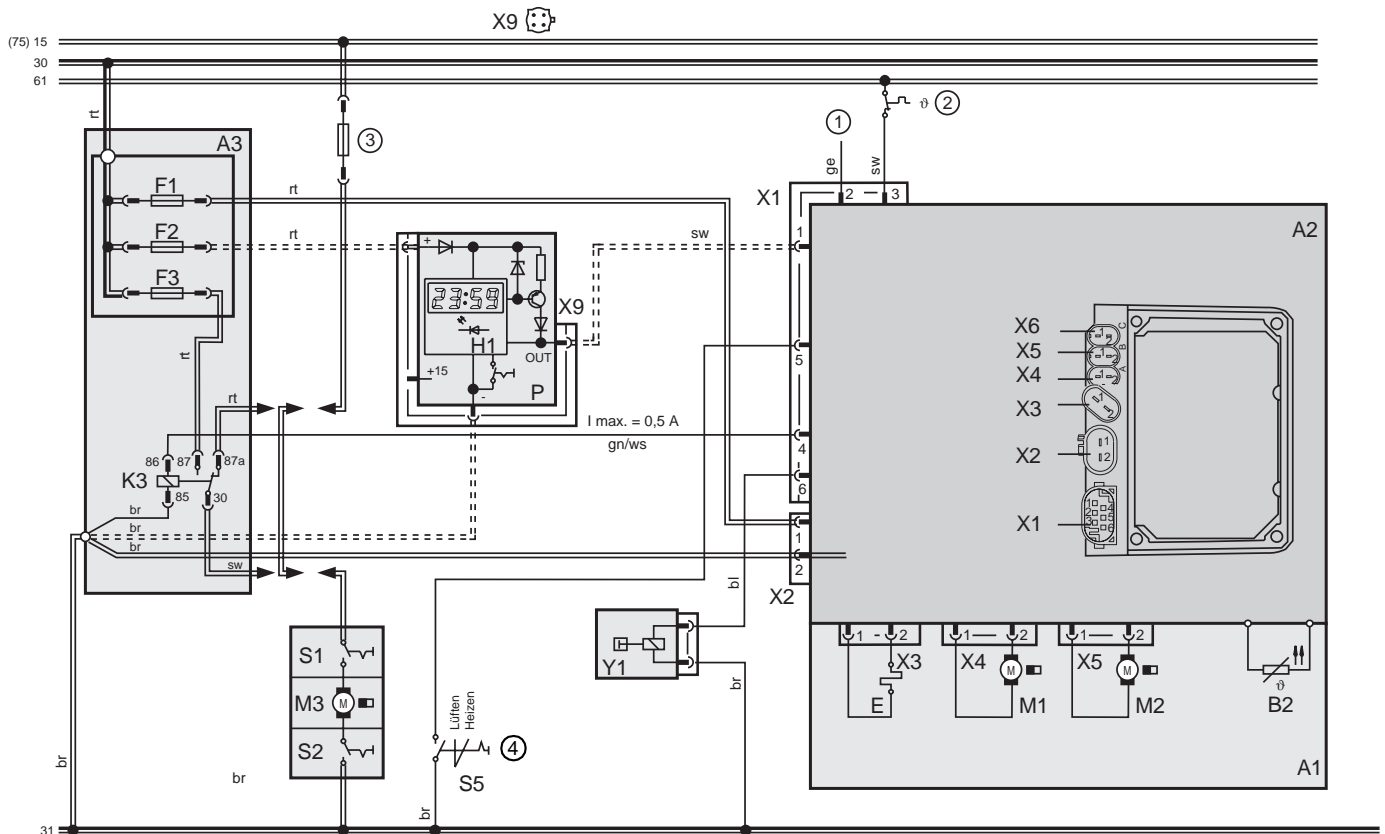

Item	Nomenclature	Remark
A1	Heater	Thermo Top E or Z/C
A2	Control unit	
A3	Connector box	
B2	Temperature sensor	
E	Glow plug / flame sensor	
F1	Fuse 20 A	Flat fuse SAE J 1284
F2	Fuse 1 A	Flat fuse SAE J 1284
F3	Fuse 25 A	Flat fuse SAE J 1284
H1	LED (in item P)	operating indicator light
K3	Relay (in item A3)	vehicle air fan
M1	Motor	combustion air fan
M2	Motor	circulation pump
M3	Motor	vehicle air fan
P	Timer, digital	for timer operation
S1	Switch for vehicle air fan	depending on vehicle S1 or S2
S2	Switch for vehicle air fan	depending on vehicle S1 or S2
S5	Switch	summer/winter switch
X1	Connection, 6-pole	
X2	Connection, 2-pole	water repellent
X3	Connection, 2-pole	water repellent
X4	Connection, 2-pole	water repellent
X5	Connection, 2-pole	water repellent
X6	Connection, 2-pole	water repellent
X9	Connection, 4-pole	
Y1	Dosing pump	

Wire Gauges		
	< 7.5 m	7.5 - 15 m
⋯⋯⋯⋯	0,5 mm <sup>2</sup>	0,75 mm <sup>2</sup>
— — — —	0,75 mm <sup>2</sup>	1,5 mm <sup>2</sup>
— — — —	1,5 mm <sup>2</sup>	2,5 mm <sup>2</sup>
— — — —	2,5 mm <sup>2</sup>	4,0 mm <sup>2</sup>
— — — —	4,0 mm <sup>2</sup>	6,0 mm <sup>2</sup>

Wire Colours	
bl	blue
br	brown
ge	yellow
gn	green
gr	grey
or	orange
rt	red
sw	black
vi	violet
ws	white

Legend for circuit diagrams

- ① Diagnosis
- ② Outside air temperature
- ③ Vehicle heating air fan fuse provided in vehicle
- ④ Option

Fig. 703 Automatic Switching Circuit for Thermo Top E and Z/C, 12 V Timer

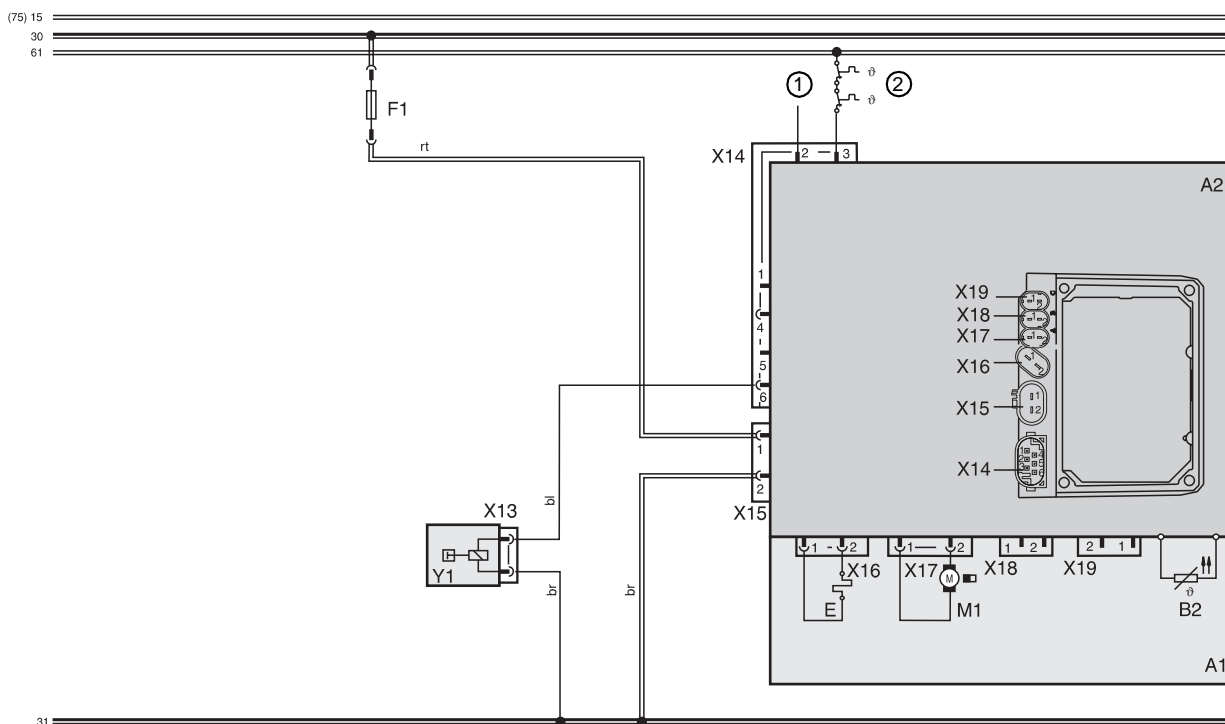

Item	Nomenclature	Remark
A1	Heater	Thermo Top Z
A2	Control unit	
B2	Temperature sensor	
E	Glow plug / flame sensor	
F1	Fuse 20 A	Flat fuse SAE J 1284
M1	Motor	combustion air fan
X13	Connection 2-pole	
X14	Connection 6-pole	water repellent
X15	Connection 2-pole	water repellent
X16	Connection 2-pole	water repellent
X17	Connection 2-pole	water repellent
X18	Connection 2-pole	water repellent
X19	Connection 2-pole	water repellent
Y1	Dosing pump	

Wire Gauges		
	< 7.5 m	7.5 - 15 m
.....	0,5 mm <sup>2</sup>	0,75 mm <sup>2</sup>
----	0,75 mm <sup>2</sup>	1,5 mm <sup>2</sup>
———	1,5 mm <sup>2</sup>	2,5 mm <sup>2</sup>
====	2,5 mm <sup>2</sup>	4,0 mm <sup>2</sup>
=====	4,0 mm <sup>2</sup>	6,0 mm <sup>2</sup>

Wire Colours	
bl	blue
br	brown
ge	yellow
gn	green
gr	grey
or	orange
rt	red
sw	black
vi	violet
ws	white

Legend for circuit diagrams

- ① Diagnosis
- ② Outside air temperature

Fig. 704 Automatic Switching Circuit for Thermo Top Z, 12 V

## 8 Servicing

### 8.1 General

This section describes the servicing procedures allowed on the heater when installed.

#### WARNING

There is a potential danger of skin burns as the heater and its components may be very hot.

### 8.2 Work on the Heater

For any type of work on the heater the main power supply cable is to be disconnected from the vehicle battery. As long as the heater is in operation or in run-down the battery main power supply must not be disconnected to prevent the heater from overheating by response of the overheat protection. When performing long time repairs on the heater its removal is compulsory. After repairs on the heating circuit it must be replenished with a mixture of coolant and water to manufacturer's instructions followed by careful bleeding of the circuit. Repairs requiring a change of location the relevant installation instructions and the vehicle specific heater installation proposal have to be observed.

### 8.3 Work on the Vehicle

#### CAUTION

In the vicinity of the heater a temperature of 120° C must under no circumstances be exceeded (e.g. during paint work on the vehicle).

### 8.4 Heater Test Run

The heater must not be operated, not even with the timer, in enclosed areas like garages or workshops not provided with exhaust ventilation facilities.

### 8.5 Servicing

To ensure functional reliability of the heater the following servicing must be performed in regular intervals:

- clean air heater exterior (prevent the ingress of water).
- examine electrical connections for corrosion of contacts and for security.
- inspect combustion air and exhaust ducting for damage and obstructions.

- inspect fuel lines and fuel filter for leakage.
- inspect coolant circuit and circulation pump (Thermo Top E and C only) for leakage.
- inspect hoses for cracks.
- replace fuel filter, if installed.

## 8.6 Visual Inspections and Installation Regulations

### 8.6.1 Connection to Vehicle Cooling System

The installation location of the heater should be as low as possible to ensure self-venting of the heater and circulation pump. This applies in particular to the circulation pump (Thermo Top E and C only), which is not self-sucking.

The circulation pump may be installed in the location provided on the heater or remote from the heater integrated in the coolant circuit. The correct direction of flow through the heater must be observed (coolant outlet on top, coolant inlet on bottom), otherwise malfunctions may result.

The heater is to be connected to the vehicle cooling system according to Fig. 801 or 802. The amount of coolant used in the circuit must be at least 4 litres.

The heater integration into the cooling circuit must be upstream of the vehicle's own heat exchanger.

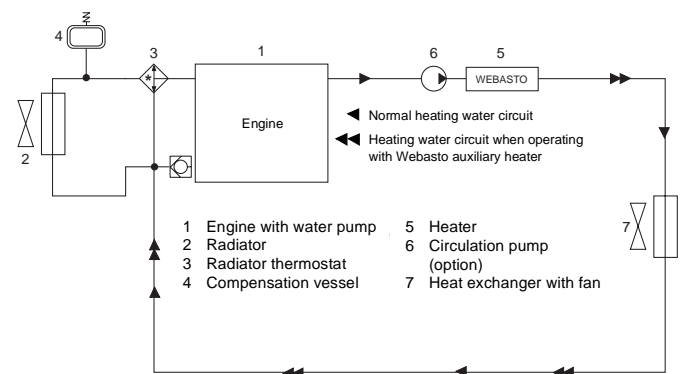

Fig. 801  
"Inline Integration" in the Engine Water Cooling Circuit



The coolant hoses supplied by Webasto must be installed, other hoses must meet at least the DIN 73411 requirement. The hoses are to be routed upwards as far as possible and without kinks to ensure proper venting. Hose connections must be protected against slippage using hose clamps.

Prior to the heater's first operation or after renewal of the coolant the cooling system must be carefully bled. The heater and the lines must be installed to ensure static venting.

Insufficient venting may cause overheating during heater operation.

**NOTE**

The installation of the hose clamps of the heater must be between the bead and the heater. The hose clamps must be torque tightened to 2.0 + 0.5 Nm.

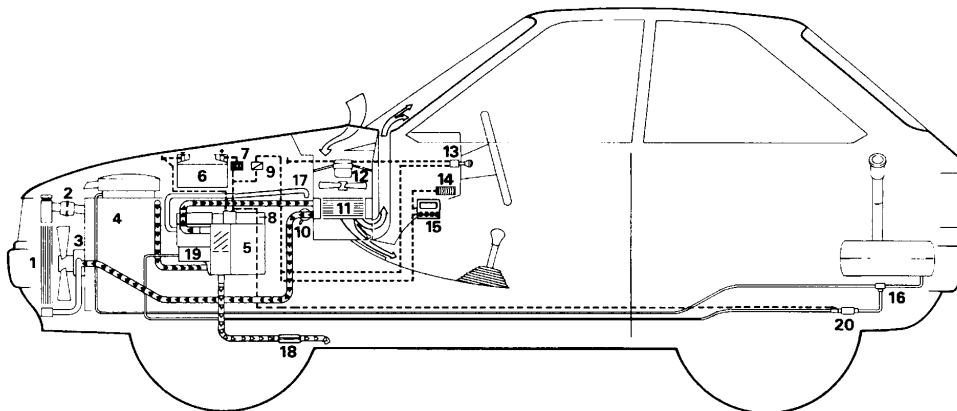

- |   |  |
|---|--|
| 1 Radiator                                  | 12 Air fan of vehicle heating system                             |
| 2 Coolant thermostat                        | 13 Switch for air fan of vehicle heating system                  |
| 3 Water pump (of vehicle engine)            | 14 Fuse box in vehicle   |
| 4 Vehicle engine with standard outfit       | 15 Timer   |
| 5 Water heater                              | 16 Fuel tapping  |
| 6 Battery                                   | 17 Air intake muffler  |
| 7 Fuse holder                               | 18 Exhaust muffler   |
| 8 Control unit (in heater)                  | 19 Circulation pump (only applicable for supplementary heating)* |
| 9 Relay (for vehicle air fan)               | 20 Fuel dosing pump  |
| 10 Control valve of vehicle heating system  | * part of modification kit                                       |
| 11 Heat exchanger of vehicle heating system |  |

Fig. 802 Example for Heater Installation in Passenger Vehicle

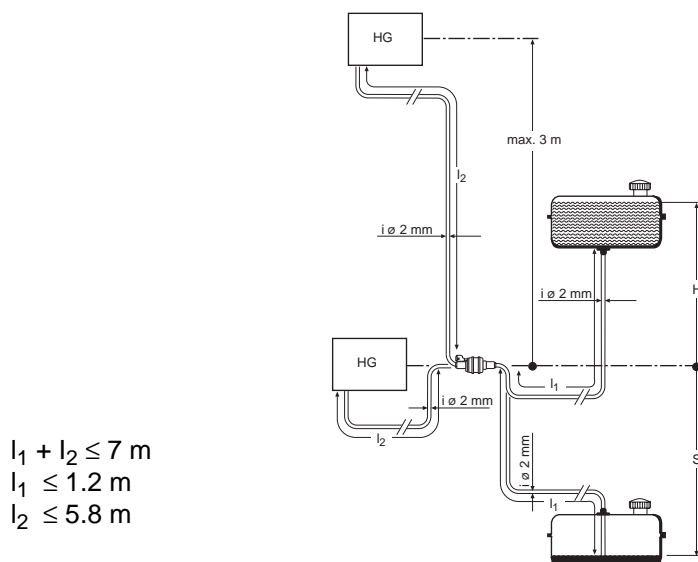

$$l_1 + l_2 \leq 7 \text{ m}$$

$$l_1 \leq 1.2 \text{ m}$$

$$l_2 \leq 5.8 \text{ m}$$

Fig. 803 Fuel Supply

**8.6.2 Connection to Vehicle Fuel System**

In vehicles with carburettor or fuel injection including a return line the heater fuel system integration must be according to Fig. 802.

Carburettor engines without return line must have the heater integrated in the fuel system's fuel supply line between fuel tank and vehicle fuel pump.

**NOTE**

A fuel supply line can normally be identified by the installation of a fuel filter. If the degassing vessel is included in the vehicle fuel system installation, the fuel tap must be located upstream of the degassing vessel.

The following table lists the pressures permitted at the fuel tapping location.

Permitted fuel feed height (H) m	at max. permissible overpressure (bar) in fuel line
0.00	0.20
1.00	0.11
Permitted suction height S (m)	at max. permissible negative pressure (bar) in fuel tank
0.00	- 0.10
0.50	- 0.06
1.00	- 0.02

Fuel tappings from the supply or return line may only use the special Webasto fuel tap.

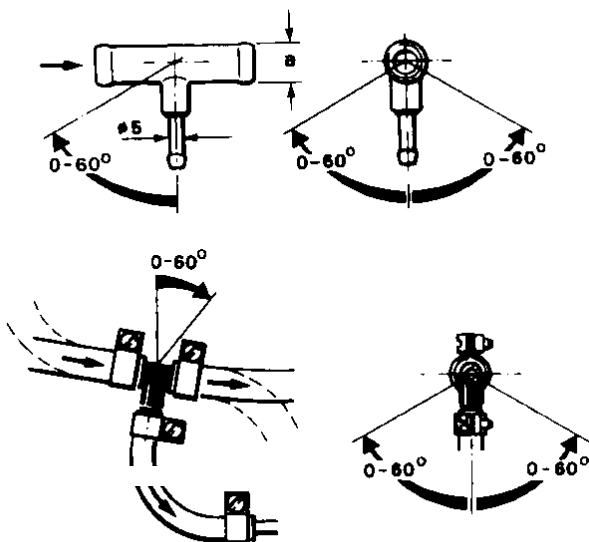

Fig. 804 Webasto Fuel Tap

The fuel tap is to be mounted so that air or gas bubbles may escape towards the fuel tank.

Air or gas bubbles may build up in the vehicle fuel line in case the carburettor or the fuel pump is leaking or if ambient temperatures exceed the fuel evaporation temperature.

The fuel tap should not be located near the engine, as gas bubbles may build up due to the heat radiated by the engine resulting in malfunctions of combustion operation.

When installing the heater in vehicles with fuel injection system, the fuel pump location, internal or external of the fuel tank, must be investigated.

With a fuel pump located inside the fuel tank, fuel may be tapped only from the return line, ensuring that the return line is routed almost all the way down to the fuel tank floor. Otherwise the return line may be lengthened.

**NOTE**

If the fuel return line is provided with a check valve, a bypass must be provided.

With a fuel pump located outside of the fuel tank the fuel tap may be located between tank and fuel pump.

**8.6.2.1 Fuel Lines**

Fuel lines may only be steel, copper, or plastic lines made of unhardened, light and temperature stabilised PA 11 or PA 12 (e.g. Mecanyl RWTL) according to DIN 73378.

As in most cases a permanently rising fuel line routing cannot be ensured, the inner diameter must not exceed a certain value. Starting from an inside diameter of 4 mm, air or gas bubbles accumulate resulting in malfunctions should the lines be descending or having sags. The diameters specified in Fig. 803 ensure no disturbing formation of bubbles.

A descending line routing from the dosing pump to the heater should be avoided.

Loose fuel lines must be secured in order to avoid sagging. The installation must ensure protection against stone impacts and undue temperatures (exhaust line).

**NOTE**

Hose clamps must be torque tightened to 1.0 + 0.4 Nm.

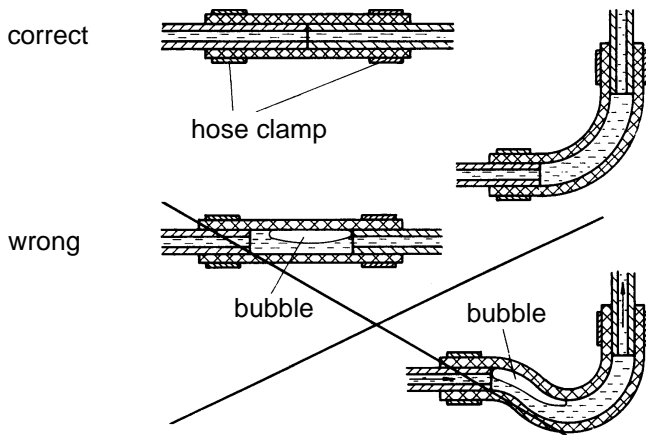

Fig. 805 Pipe/Hose Connection

8.6.2.2 Dosing Pump

The dosing pump is a combined delivery, dosing and shut-off system and is subject to certain installation criteria (Fig. 803 and 806).

Concerning the installation location of the dosing pump it must be ensured that the maximum pressure at the tapping location is below the permissible value (see table of 8.6.2.).

It is advantageous to mount the dosing pump in a cool location. The ambient temperature must never exceed + 20° C during operation.

Dosing pump and fuel lines must not be installed in locations exposed to heat radiated by hot vehicle components. A heat shield is to be provided as necessary.

The preferred installation location is near the tank.

The dosing pump is to be attached with an anti-vibration mount. The installation position is limited according to Fig. 806 to ensure sufficient self-venting capability.

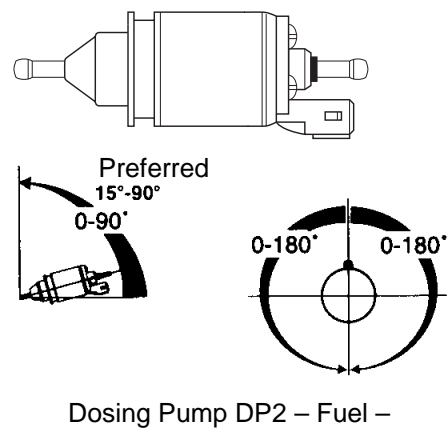

Dosing Pump DP2 – Fuel –

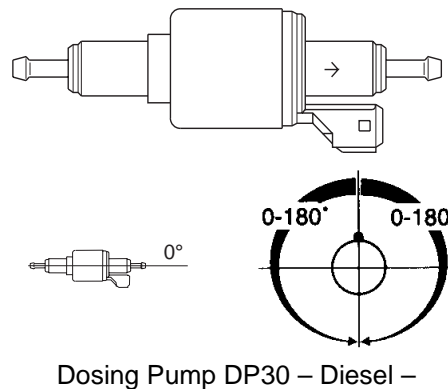

Dosing Pump DP30 – Diesel –

Fig. 806 Dosing Pump, Installation Position

8.6.2.3 Combustion Air Supply

A combustion air intake line is required.

The combustion air intake location must be protected against splash water.

The combustion air line may be routed in several bends (total of 270°, smallest bending radius 50 mm). The maximum line length without air intake muffler is 1000 mm.

**NOTE**

When using the air intake muffler the maximum air line length is 400 mm.

The combustion air must under no circumstances be taken in from rooms accommodating persons. If the heater is contained in an installation box, a vent hole of at least 3 cm<sup>2</sup> is required.

Should the temperature within the installation box exceed the permitted ambient temperature of the heater, the vent hole must be enlarged after consulting Webasto.

The combustion air intake must be located so that clogging by contamination is not to be expected. The intake must **not** point in the direction of forward motion.

When installing the heater in the vicinity of the vehicle fuel tank in a common installation compartment, the

combustion air must be taken in from and the exhaust vented to the exterior. The line feedthroughs must be sealed against splash water.

**8.6.3 Air Intake Muffler**

The permitted installation position of the air intake muffler is between 0° and 90° pointing downwards.

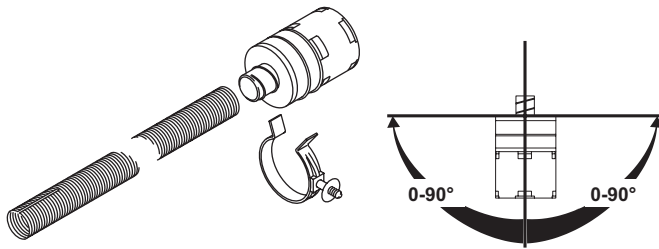

Fig. 807 Air Intake Muffler, Installation Position

**8.6.3.1 General Remarks for Installation**

Plug air intake hose with its slotted end (approx. 18 mm) onto air intake connecting pipe of heater and fasten with hose clamp.

Screw air intake muffler all the way into unslotted end of combustion air intake hose (additional fastening with hose clamp not required).

**CAUTION**

Ensure sufficient distance to exhaust system.

Dependent on installation area fasten air intake muffler with retaining clip or with cable ties in suitable location.

**8.6.4 Exhaust Line**

The exhaust line (inner diameter 22 mm) may be routed in several bends (total of 270°, smallest bending radius 50 mm). The minimum line length is 500 mm, the maximum length is 1000 mm.

The exhaust muffler is to be mounted near the heater, however at least 200 mm away from the heater. The exhaust muffler must not be installed near the combustion air intake. Heater operation without exhaust muffler is not permitted.

**NOTE**

Accumulations of condensate in the exhaust line must be directly drained. A condensate drain hole (3 mm Ø) may be provided as required.

The exhaust line outlet must not point in the direction of forward motion (Fig. 808)

Rigid pipes of unalloyed steel with a minimum wall thickness of 1.0 mm or flexible hoses of alloyed steel only may be used as exhaust ducts.

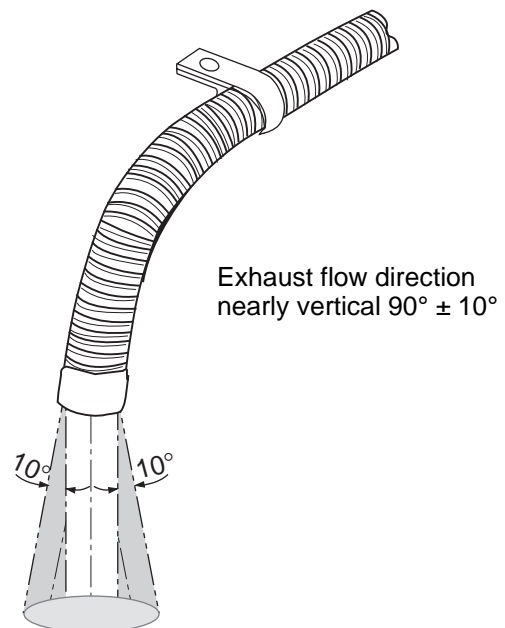

Fig. 808 Exhaust Pipe Outlet, Installation Position

## 8.7 Removal and Installation

### CAUTION

In the heater installed condition only the circulation pump removal and installation is permitted should accessibility allow for such action (see 9.2.1).

### 8.7.1 Heater, Removal and Installation

#### 8.7.1.1 Removal

1. Disconnect heater power supply by removing 20 A flat fuse (yellow) from Webasto fuse holder.
2. Disconnect electrical connections from heater. Disconnect antenna cable to Telestart receiver T60 at screw type locking connector.
3. Open radiator cap for depressurisation, then close cap.

### NOTE

Collect coolant escaping in a vessel or prevent coolant from escaping by using squeezing tongs.

4. Loosen hose clamps and disconnect coolant hoses from heater.
5. Loosen heater from its mount.
6. Loosen hose clamps, disconnect fuel line and close with suitable plug or any other means.

#### 8.7.1.2 Installation

1. Locate heater for installation.
2. Connect fuel line to heater and secure with hose clamp.
3. Connect coolant hoses and secure with spring band steel clamps.
4. Restore all electrical connections at connector terminal.
5. Connect antenna cable to Telestart T60 receiver as required.
6. Re-install 20 A flat fuse (yellow) in fuse holder.
7. Bleed coolant circuit.
8. Bleed fuel system as required.

## 8.7.2 Timer, Removal and Installation

Timer removal and installation is to be performed in accordance with Fig. 809. For initial installation use drilling stencil. The electrical connection is shown in Section 7.

### CAUTION

During installation do not exert pressure on display.

### NOTE

Only the timer shown in Fig. 809 may be used in combination with the heater.

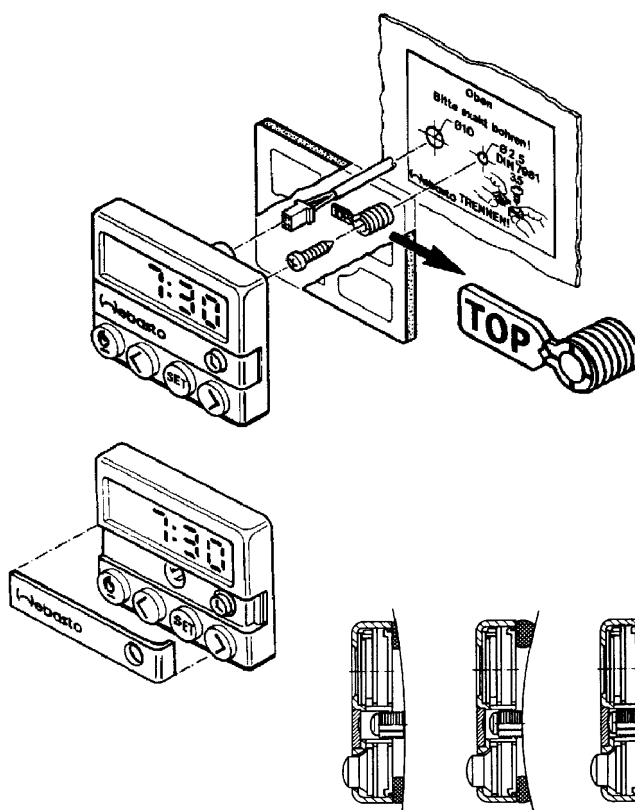

Fig. 809 Timer, Removal and Installation

## 8.8 Initial Operation

After heater installation the coolant circuit as well as the fuel supply system must be carefully bled observing the relevant manufacturer's instructions.

During the heater test run inspect all coolant and fuel connections for leakage and security. Should the heater during operation enter an error lockout condition, perform troubleshooting (see Section 5).

## **9 Repair**

### **9.1 General**

This section describes the repairs that may be performed on the heaters Thermo Top Z and Thermo Top E and C when removed. Any further disassembly will void the warranty. After repairs a functional test must be performed.

#### **9.1.1 Work on Components after Disassembly**

##### **CAUTION**

All gaskets located between disassembled components must always be discarded and replaced.

##### **9.1.1.1 Cleaning**

- All components disassembled must be cleaned.
- Sealing compound on components must be carefully and completely removed using suitable means.

##### **9.1.1.2 Visual Inspection**

- Inspect all components for damages (cracks, deformation, wear, etc.) and replace as required.
- Inspect connectors and wiring for corrosion, loose contacts, wrong crimping, etc. and repair as required.
- Inspect connector terminal for corrosion and contacts for security.

9.2 Disassembly and Assembly

9.2.1 Circulation Pump, Replacement (Thermo Top E and C)

9.2.1.1 Removal

1. Remove cover (4, Fig. 901) and disconnect electrical connector of circulation pump.
2. Loosen spring band steel clamp (5, Fig. 901).
3. Remove screw (7) and clamp (2).
4. Withdraw circulation pump (6) and remove spring band steel clamp (5).
5. Withdraw collar (1) as required.
6. Perform procedures on components after disassembly (refer to 9.1.1).

9.2.1.2 Installation

1. Slide spring band steel clamp (5, Fig. 901) onto hose end.
2. Position collar (1) on circulation pump (6) as required.
3. Locate circulation pump (6) for installation and secure with clamp (2) and screw (7) on combustion air fan (3).
4. Position spring band steel clamp (5).
5. Torque screw (7) with  $3.5 \pm 0.3$  Nm.
6. Connect circulation pump electrical connection and fit cover (4).

**NOTE**  
Circulation pump may also be mounted remotely in vehicle.

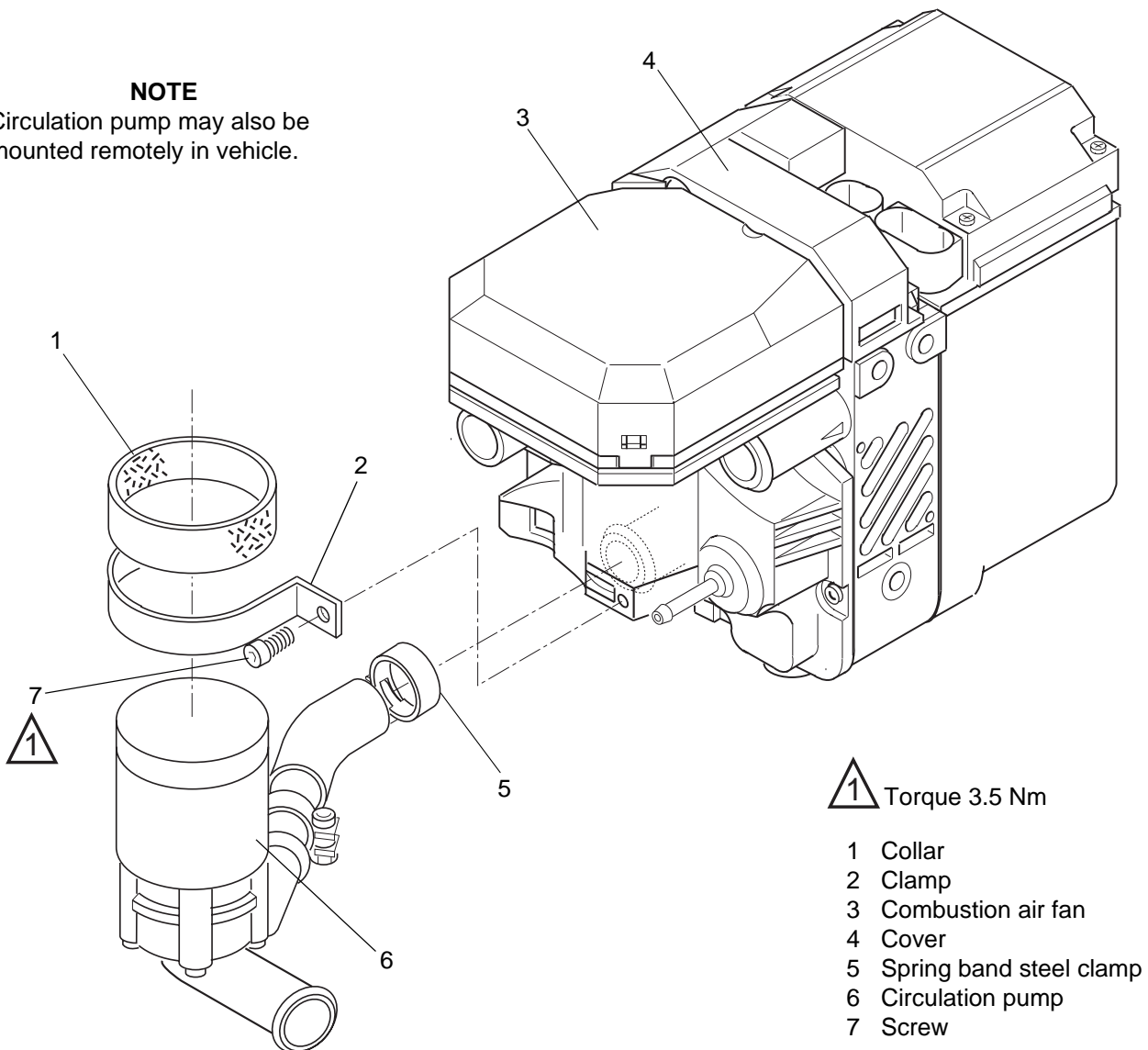

Fig. 901 Replacement of Circulation Pump (Thermo Top E and C)

**9.2.2 Combustion Air Fan, Replacement**

**CAUTION**

In case of Thermo Top E and C the circulation pump must be removed first (see 9.2.1.1).

**9.2.2.1 Removal**

1. Carefully lever off cover (6, Fig. 902).
2. Disconnect electrical connector of combustion air fan.
3. Remove screws (11).
4. Withdraw combustion air fan (1) from burner housing (5) and fuel pipe (9).
5. Remove gasket (2) and discard.
6. Perform procedures on components after disassembly (refer to 9.1.1).

**9.2.2.2 Installation**

**CAUTION**

For the sealing between combustion air fan and burner housing two gaskets (2, Fig. 902) are available or contained in the spares kit. One paper gasket and one rubber gasket with beads on one side to be used as follows:

**NOTE**

A new combustion air fan has a groove for the gasket in the mounting flange fan to burner housing.

Combustion air fan **new** –  
Control unit / heat exchanger with burner housing  
**new = rubber gasket**

Combustion air fan **old** –  
Control unit / heat exchanger with burner housing  
**old = paper gasket**

Combustion air fan **old** –  
Control unit / heat exchanger with burner housing  
**new = paper gasket**

Combustion air fan **new** –  
Control unit / heat exchanger with burner housing  
**old = rubber gasket**

1. Position new gasket (2) on burner housing (3).
2. Slide combustion air fan (1) onto fuel pipe (9) to bring fan into installation position.
3. Secure combustion air fan (1) with screws (11).  
Torque tighten screws to  $4 \pm 0.4$  Nm.

4. Plug on electrical connections of combustion air fan.
5. Install circulation pump as required (see 9.2.1.2).
6. Plug on cover (6) and engage.
7. Perform CO<sub>2</sub> setting (see 6.2.6).



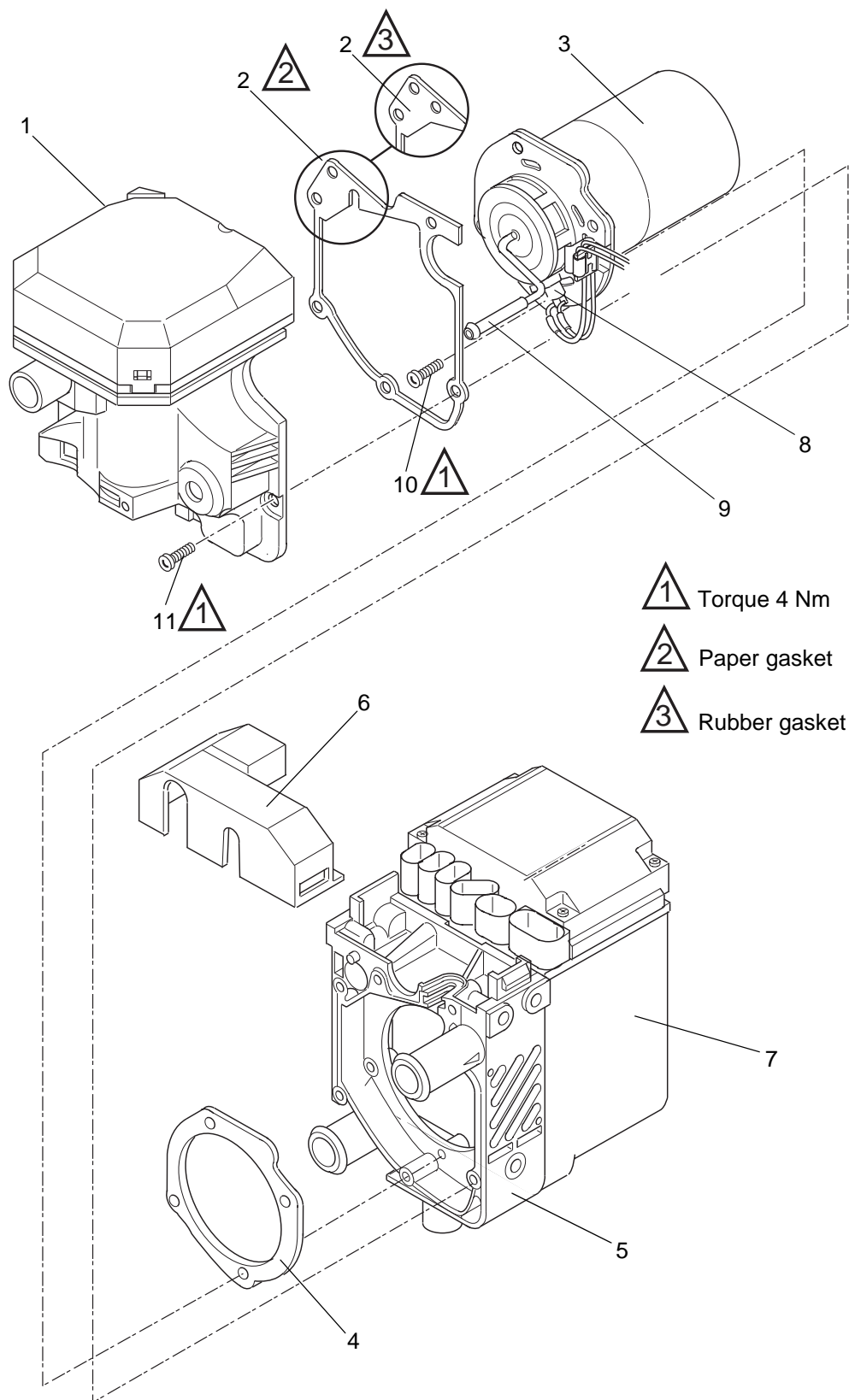

- |   |                    |    |                               |
|---|--------------------|----|-------------------------------|
| 1 | Combustion air fan | 7  | Control unit / heat exchanger |
| 2 | Gasket             | 8  | Glow plug / flame sensor      |
| 3 | Burner insert      | 9  | Fuel pipe                     |
| 4 | Gasket             | 10 | Screw (4)                     |
| 5 | Burner housing     | 11 | Screw (4)                     |
| 6 | Cover              |    |                               |

Fig. 902 Heater Disassembly

**9.2.3 Burner Insert with Glow Plug / Flame Sensor, Replacement****CAUTION**

In case of Thermo Top E and C the circulation pump must be removed first (see 9.2.1.1).

**9.2.3.1 Removal**

1. Remove combustion air fan (see 9.2.2.1).
2. Push grommet of cable of glow plug / flame sensor (8, Fig. 902) out of burner housing (5).
3. Remove screws (10).
4. Withdraw burner insert (3) with glow plug / flame sensor (8) from burner housing (5).
5. Remove gasket (4) and discard.
6. Perform procedures on components after disassembly (refer to 9.1.1).

**9.2.3.2 Installation**

1. Position new gasket (4) on burner housing (5).
2. Position burner insert (3) for assembly and secure with screws (10). Torque tighten screws to  $4 \pm 0.4$  Nm.
3. Press grommet of glow plug / flame sensor cable into burner housing (5).
4. Install combustion air fan (see 9.2.2.2).
5. Install circulation pump as required (see 9.2.1.2).

**9.2.4 Control Unit / Heat Exchanger with Burner Housing, Replacement****CAUTION**

In case of Thermo Top E and C the circulation pump must be removed first (see 9.2.1.1).

**9.2.4.1 Removal**

1. Remove combustion air fan (see 9.2.2.1).
2. Push grommet of cable of glow plug / flame sensor (8, Fig. 902) out of burner housing (5).
3. Remove screws (10).
4. Withdraw burner insert (3) with glow plug / flame sensor (8) from burner housing (5) and remove.
5. Remove gasket (4) and discard.
6. Perform procedures on components after disassembly (refer to 9.1.1).

**9.2.4.2 Installation**

1. Position new gasket (4, Fig. 902) on burner housing (5).
2. Position burner insert (3) for assembly and secure with screws (10). Torque tighten screws to  $4 \pm 0.4$  Nm.
3. Press grommet of glow plug / flame sensor cable into burner housing (5).
4. Install combustion air fan (see 9.2.2.2).
5. Install circulation pump as required (see 9.2.1.2).



## **10 Packaging, Storage and Shipping**

### **10.1 General**

The heater or its components shipped to Webasto Thermosysteme GmbH for testing or repair must be cleaned and packaged so that they are protected against damage during handling, shipping and storage.

#### **CAUTION**

When shipping a complete heater assembly it must be drained completely.

No fuel is allowed to escape from a packaging or during shipping.

Dummy plugs must be fitted to the fuel and coolant connector pipes.

