

Workshop manual

Air Top 3500 ST

Air Top 5000 ST

Air Top 3500/5000 ST B (petrol)

Air Top 3500/5000 ST D (diesel)

Air Top 3500 ST D Volume Plus (diesel)

Table of contents

1	Introduction	
1.1	Contents and purpose	101
1.1.1	Using the air heaters	101
1.2	Meaning of signal words	101
1.3	Additional documentation to be used.....	101
1.4	Statutory regulations and safety instructions	101
1.4.1	Regulations for installation in the vehicle	101
1.4.2	General safety information	102
1.5	Suggestions for improvements and modifications	104
2	General description	
2.1	Drive unit.....	202
2.2	Heat exchanger	202
2.3	Burner insert with burner pipe.....	202
2.4	Control unit	203
2.5	Glow plug/Flame sensor	203
2.6	Overheating sensor	203
2.7	Metering pump.....	203
3	Function description	
3.1	Control element	301
3.2	Switch on	301
3.3	Heating mode	301
3.4	Control mode	301
3.5	Control pause	302
3.6	Switch off	302
3.7	Heater functions when installed in ADR vehicles	302
3.8	Fault lock-out	302
3.8.1	Error monitor.....	303
3.8.2	Reset a fault lock-out.....	303
4	Technical data	401

5 Troubleshooting

5.1	General	501
5.2	General error symptoms	501
5.3	Error symptoms during function	502
5.4	Fault code output	503

6 Function tests

6.1	General	601
6.2	Settings	601
6.2.1	Setting the CO ₂ content	601
6.3	Testing individual components	601
6.3.1	Resistance test on the glow plug/flame sensor	601
6.3.2	Resistance test on the overheating sensor	601

7 Circuit diagrams

7.1	General	701
-----	---------------	-----

8 Servicing work

8.1	General	801
8.2	Work on the heater	801
8.3	Work on the vehicle	801
8.4	Heater trial	801
8.5	Servicing work	801
8.6	Visual inspections and installation instructions	801
8.6.1	Hot air system	801
8.6.2	Fuel supply	802
8.6.3	Metering pump	804
8.6.4	Fuel filter	804
8.6.5	Combustion air supply	805
8.6.6	Exhaust pipe	805
8.6.7	Combustion air intake and exhaust pipes	805
8.6.8	Electrical connections	806
8.7	Removal and installation	
8.7.1	Heater, removal and installation	808
8.8	Start-up	808

9 Repair

9.1	General	901
9.1.1	Working on components after they have been dismantled.....	901
9.1.2	Carrying out modifications	901
9.2	Dismantling and assembling.....	902
9.2.1	Remove the casing parts	902
9.2.2	Fit the casing parts	902
9.2.3	Change the control unit	904
9.2.4	Change the overheating sensor	904
9.2.5	Change the combustion and hot air blower (drive unit)	904
9.2.6	Change the burner and the glow plug/flame sensor	906
9.2.7	Change the combustion pipe and the heat exchanger	906

10 Packaging, storage and shipping

10.1	General	1001
------	---------------	------

List of illustrations

501	General error symptoms	501
502	Error symptoms during function	502
503	Troubleshooting	503
701	Plug assignment	701
702	System circuit diagram 12V/24V with control element and vehicle blower	702
703	System circuit diagram 12V/24V with combination timer and vehicle blower	703
704	System circuit diagram 12V/24V with combination timer and electrical battery isolation switch.....	704
705	System circuit diagram 24V (diesel) ADR operation with control element.....	705
706	System circuit diagram 24V (diesel) ADR operation with control element without auxiliary drive unit.....	706
707	Schematic connection of the combination timer	707
801	Fuel supply.....	802
802	Webasto fuel extractor	803
803	Fuel extraction from the plastic tank (extraction through tank drain screw)	803
804	Fuel extraction from the plastic tank (extraction through tank fittings)	803
805	Pipe/Hose connections	804
806	Metering pump, installation position.....	804
807	Fuel filter	804
808	Exhaust silencer.....	805
809	Exhaust pipe mouth, installation position.....	805
810	Remove the fastening plate on the fuse holder	806
811	Fuse holder, installation position.....	806
812	Control element.....	806
813	Disconnect the plug	806
814	Specimen installation for heater in air circulation mode.....	807
901	Remove / Fit the casing parts	903
902	Change the control unit, overheating sensor and the combustion and hot air blower (drive unit)	905
903	Change the burner, glow plug/flame sensor, the combustion tube and the heat exchanger	907

1 Introduction

1.1 Contents and purpose

This workshop manual is designed to assist trained personnel with repairing both the petrol and the diesel versions of the Air Top 3500/5000 ST air heaters.

1.1.1 Use of the air heaters

The Webasto Air Top 3500 ST and Air Top 5000 ST air heaters are designed

- to heat cabins, boats, trucks, minibuses, vans, ambulances and motorhomes.
- to defrost vehicle windows.
- to heat cargo.

They are not designed for heating cargo areas used to carry hazardous substances.

The heaters operate independently of the engine and are connected to the fuel tank and the electrical system of the vehicle.

They are not designed for installation in vehicles with water or air-cooled engines.

1.2 Meaning of signal words

Throughout this manual, the signal words WARNING, CAUTION and NOTE have the following meanings:

WARNING

This heading is used to highlight operating instructions or procedures which, if not or not correctly followed, may result in personal injury or fatal accidents.

IMPORTANT

This heading is used to highlight operating instructions or procedures which, if not or not correctly followed, may result in damage to the equipment or its components.

NOTE

This heading is used to direct your attention to a special feature deemed essential to highlight.

1.3 Additional documentation to be used

This workshop manual contains all the information and instructions required for repairing the Air Top 3500 ST and Air Top 5000 ST air heaters.

Normally, there is no need to use additional documentation. If necessary the operating / installation instructions and the installation suggestion for the specific vehicle may also be used.

1.4 Statutory regulations and safety instructions

In principle, the general accident prevention regulations and current works safety instructions are applicable. The "General safety regulations" that go beyond the scope of the above regulations are stated below. Any special safety regulations relevant to this instruction manual will be highlighted in the relevant sections or text passages of the procedures.

1.4.1 Statutory regulations governing installation

The Air Top 3500 ST / Air Top 5000 ST heaters have been type-tested and approved in accordance with EC Directives 72/245/EEC (EMC) and 2001/56/EC (heater) with the following EC permit numbers:

e1*72/245*95/54*1221*00
e1*2001/56*0021*00
e1*2001/56*0020*00

Installation is governed above all by the provisions in Annex VII of Directive 2001/56/EC.

NOTE

The provisions of these Directives are binding within the territory governed by EU Directive 70/156/EEC and should similarly be observed in countries without specific regulations.

(Extract from Directive 2001/56/EC Annex VII)

1.7.1. A clearly visible indicator within the user's field of vision must show whether the heater is switched on or off.

2. Regulations for installation in the vehicle

2.1. Scope

- 2.1.1. Subject to the provisions of paragraph 2.1.2, internal combustion heaters must be installed in accordance with the requirements contained in this Annex.
- 2.1.2. In the case of class O vehicles (trailers) with heaters for liquid fuel, it is presumed that these vehicles comply with the requirements in this Annex.

2.2. Position of the heater

- 2.2.1. Parts of the vehicle body and other components in the immediate vicinity of the heater must be protected against excessive heat and the danger of contamination by fuel or oil.

2.2.2. The internal combustion heater must not pose a fire hazard even when overheated. This requirement is deemed to have been met if care is taken during installation to ensure an adequate distance from all parts, as well as adequate ventilation and if fire-resistant materials or heat shields are used.

2.2.3. In class M2 and M3 vehicles the heater must not be installed in the passenger cabin. A device in a sealed cover, which also meets the requirements set out in paragraph 2.2.2, may be used, however.

2.2.4. The plate mentioned in paragraph 1.4 (model plate) or a duplicate thereof (duplicate model plate) must be fitted in such a way that it is still clearly legible when the heater has been installed in the vehicle.

2.2.5. When positioning the heater, all reasonable precautions must be taken to minimise the risk of personal injury or damage to items in the vehicle.

2.3. Fuel supply

2.3.1. The fuel filler neck must not be located in the passenger compartment and must have a tightly fitting cap to prevent any fuel leaks.

2.3.2. The type of fuel and the fuel filler neck must be clearly identified on heaters for liquid fuel, for which the fuel supply is separate from the fuel supply for the vehicle.

2.3.3. A sign must be affixed to the fuel filler neck warning that the heater must be switched off before refuelling. An identical warning must also be included in the manufacturer's operating instructions.

2.4. Exhaust system

2.4.1. The exhaust outlet must be positioned in such a way that exhaust fumes cannot get into the interior of the vehicle through ventilation devices, hot-air inlets or open windows.

2.5. Combustion air inlet

2.5.1. The air for the combustion chamber of the heater must not be extracted from the passenger cabin of the vehicle.

2.5.2. The air inlet must be positioned in such a way that it cannot be obstructed by other objects.

2.6. Hot air inlet

2.6.1. The supply of heating air must consist of either fresh air or recirculated air and must be taken from a clean area which cannot be contaminated by exhaust fumes from the engine, the internal combustion heater or any other source in the vehicle.

2.6.2. The inlet line must be protected by a grating or other suitable means.

2.7. Hot air outlet

2.7.1. Hot air lines within the vehicle must be positioned or protected in such a way as to exclude all risk of injury or damage caused by direct contact.

2.7.2. The air outlet must be positioned or protected so that it cannot be obstructed by other objects.

2.8. Automatic control of the heating system

When the engine stops, the heating system must cut out automatically and the fuel supply must be stopped within 5 seconds.

The heating system may remain in operation if a manual unit has already been activated.

1.4.2 General safety information

The mouth of the exhaust pipe should be installed upwards, to the side or, if the exhaust pipe passes under the floor of the vehicle, to the side or rear limit of the driver's cab or the vehicle.

The function of important parts of the vehicle must not be adversely affected. It must not be possible for condensate or water to collect in the exhaust pipe. Drain holes may be used.

The electric cables and controls for the air-conditioning system must be arranged in the vehicle so that their proper functioning cannot be adversely affected in normal operating conditions.

Compliance with §§ 45 and 46 of the Road Vehicle Licensing Act must be ensured for the installation of fuel lines and the installation of additional fuel tanks.

The main points from this law:

- Fuel pipes must be designed in such a way that torsion in the vehicle, movements by the engine and the like do not have a negative effect on their durability. They must be protected from mechanical damage.
- Parts that carry fuel must be protected from heat that will adversely affect their function and positioned so that dripping or evaporating fuel cannot collect or ignite on hot parts or on electrical equipment.

The air heater's heat exchanger can be used for a maximum of 10 years and must then be replaced by the manufacturer or one of its authorised workshops using a genuine spare part. A label must then be affixed to the heater showing the date of sale and the wording "Genuine spare part".

When you change the heat exchanger it is essential that you also replace the overheating protection element (temperature sensor) to prevent possible function faults caused by using the old temperature sensor.

The Air Top 3500 ST and Air Top 5000 ST air heaters are prepared for interior installation and sealing direct on the cabin floor or a cabin wall. Non-release connections must be used in the interior for combustion air and exhaust pipes with the accessories available from Webasto. The seal between the heater mounting and the vehicle floor must always be installed, otherwise harmful emissions may get into the interior of the vehicle.

The hot and combustion air intake openings must be positioned in such a way that no water can ingress into them if the vehicle drives through a water hazard for which it has been approved.

The heater must not be installed in the driver's or passenger cabin of buses (vehicle classes M₂ and M₃). If the heater is nevertheless installed in such a place, the installation box must be tightly sealed against the vehicle interior. The installation box must have sufficient external ventilation to ensure that a maximum temperature of 40 °C is not exceeded in the box. Fault faults may occur if the temperature exceeds this level.

The heater must be switched off at filling stations and fuel tank farms because of the risk of explosion.

Wherever inflammable vapours or dust may form (for example near fuel, coal, wood dust or cereal stores or the like), the heater must be switched off because of the risk of explosion.

The heater must not be operated in enclosed areas, such as garages or workshops without an exhaust emissions

extraction system, not even using the timer, because of the risk of asphyxiation and poisoning.

In the event of lengthy heavy smoke development, unusual combustion noise or a smell of fuel, the heater must be put out of action by removing the fuse and must not be started again until it has been examined by Webasto-trained personnel. Liability claims can only be lodged if the claimant can prove that it has complied with the servicing and safety instructions.

Installation regulations for Webasto fuel tanks for supplying fuel to heaters in vehicles:

- The tank must not be installed in the passenger or driver's cabin of buses.
- The fuel filler neck must not be inside the passenger or driver's cabin in any vehicle.
- Fuel tanks for normal and super grades of petrol must not be immediately behind the front trim of the vehicle. They must be separated from the engine in such a way that in the event of an accident the fuel will not be expected to ignite. This does not apply to tractor units with an open driver's seat.

The fuel lines (Mecanyl hose) must not be immediately next to the exhaust pipe and must be thermally insulated if necessary, otherwise they will pose a fire risk. All pipes that come into contact with fuel must have sealed connections, they must not be damaged in any way and they must be checked at regular intervals (at least the same intervals as an inspection of the vehicle as a whole).

NOTE

If any damage or leaks are found on the fuel line, the heater must not be used until the damage has been rectified by an authorised Webasto workshop.

Put the heater out of action by removing the fuse.

Overheating

Keep hot air inlet and hot air outlet free of dirt and other items. Dirty, blocked air lines can cause the heater to shut down due to overheating.

After an overheating lock-out, check that the air system is clear, remove any materials that may block the air current and have any damage to the air lines repaired by an authorised Webasto workshop. After this the heater lock-out can be cancelled by switching it off and then on again. If this action does not produce the required success (if the heater overheats again) take it to an Webasto-authorised workshop.

The air outlet jets or air vents with adjustable flaps must always be opened to some extent so that the air current through the heater is not completely blocked. It must be impossible to close at least one air vent.

If the heater is installed in a storage area, you must ensure that no inflammable substances are kept in this area and that other material does not restrict the air supply to the heater.

Air lines must be securely fixed to the heater (using pipe clips, for example) and all other connection points (for example vents).

IMPORTANT

The errors described below are to be avoided at all costs:

- Do not stand on the heater or place or throw any heavy objects on the heater.
- Do not place any items of clothing, textiles or similar materials over the heater or in front of the hot air inlet and hot air outlet.
- The current of hot air from the heater must not be restricted or blocked by highly inflammable substances or materials such as rags, cleaning wool, etc.
- Inflammable or explosive substances and gases must not be placed near or in contact with the heater, the hot air line, the current of hot air or the exhaust pipe.
- The heater must not be cleaned with a high pressure cleaner.
- Do not switch the heater off at the main battery switch or battery isolation switch since otherwise it is possible that it may suffer long term damage if it is switched off frequently using the battery isolation switch and this can cause damage and negative influences on the function of the heater.

NOTE

Failure to follow the installation instructions and the notes contained therein will lead to all liability being refused by Webasto. The same applies if repairs are carried out incorrectly or with the use of parts other than genuine spare parts. This invalidates the type approval for the heater and its homologation / EC type permit.

You must read the operating manual before starting the heater for the first time.

1.5 Suggestions for improvements and changes

Complaints, improvement suggestions or corrections relating to this workshop manual should be addressed to:

Webasto AG
BU SPM / Dept ATT-I
Kraillinger Strasse 5
D-82131 Stockdorf

Phone: +49 (89) 85794 - 634
PC-Fax: +49 (89) 899 214 - 397

2 General description

The Air Top 3500 ST and Air Top 5000 ST air heaters are based on the evaporator principle and essentially consist of the following

- The drive unit with a combustion and hot air blower
- The heat exchanger
- The burner insert with combustion pipe
- The control unit.

To control and monitor it, the heater has

- a control unit with temperature sensor
- a glow plug / flame monitor
- an overheating sensor

inside it.

The fuel supply is provided from an external source using a metering pump.

If a fault occurs, an error code will be output in the display of the combination or standard timer. If the heater has a control element, the ON control light will flash. In addition the heater can be checked using a personal computer (see PC heater diagnostic operating manual).

The heater may be controlled using an external temperature sensor instead of the internal temperature sensor.

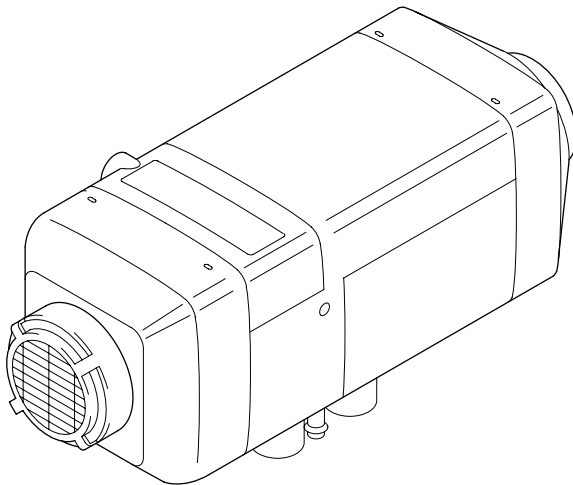

Air Top 3500/5000 ST air heater

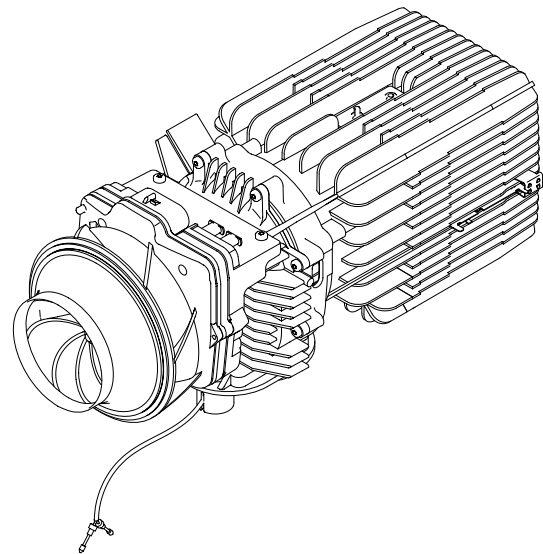

Air Top 3500/5000 ST air heater without casing

2.1 Drive unit

The drive unit consists of the drive motor, the combustion air blower, the heat air blower and the intake casing. The combustion air blower supplies the air required for the combustion process from the combustion air inlet to the burner insert.

The hot air blower transports the hot air from the hot air inlet via the heat exchanger to the hot air outlet.

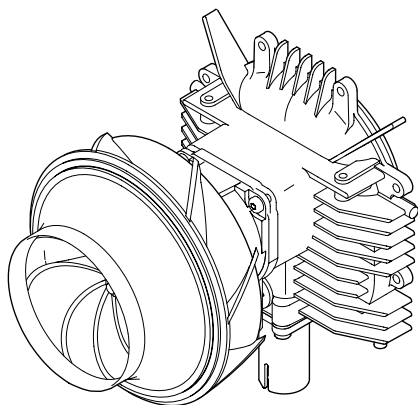

Drive unit

2.2 Heat exchanger

The heat generated by the combustion process is transferred to the air transported by the combustion and hot air blowers in the heat exchanger.

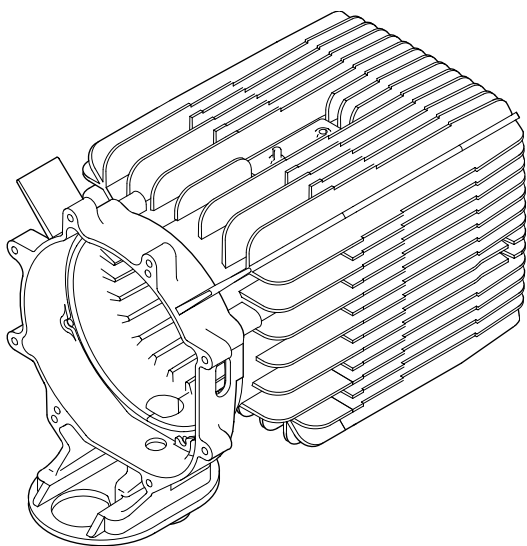

Heat exchanger

2.3 Burner insert with combustion pipe

The fuel is distributed over the burner cross-section in the combustion pipe in the burner insert. The mixture of fuel and air burns in the combustion pipe, thus causing the heat exchanger to become hot.

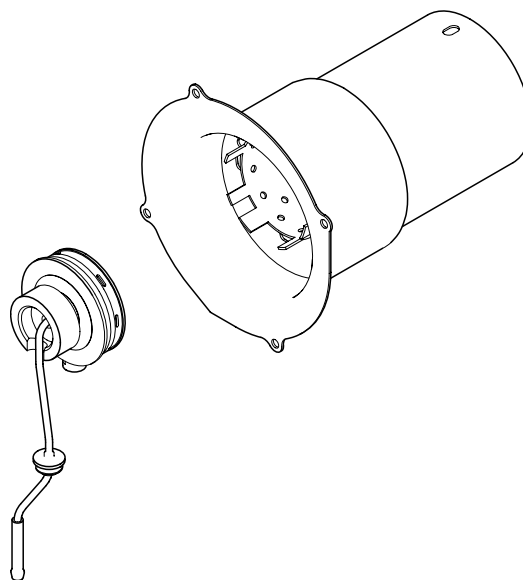

Burner insert (diesel) and combustion pipe

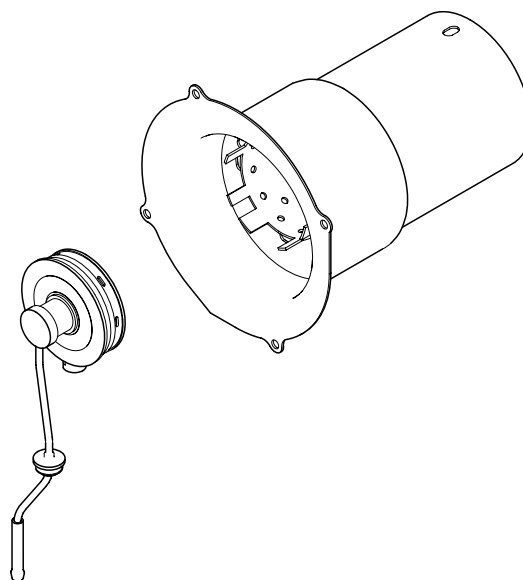

Burner insert (petrol) and combustion pipe

2.4 Control unit

The control unit is the central component for ensuring the function is maintained and for monitoring the heater's operation. A temperature sensor in the control unit is designed to control the room temperature. An external temperature may also be connected to all the heaters.

If a fault occurs, an error code will be output in the display of the combination timer. If the heater has a control element, the ON control light will flash. In addition the heater can be checked using a personal computer (see PC heater diagnostic operating manual).

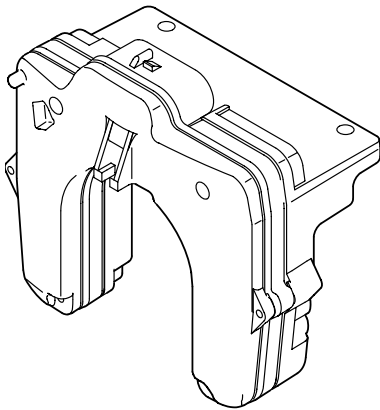

Control module

2.5 Glow plug/Flame monitor

The glow plug also acts as a flame monitor. The mixture of fuel and air is ignited by the glow plug when the heater is started. The glow plug takes the form of an electrical resistor and is positioned in the burner on the side facing the flame.

As a flame sensor the glow plug reacts in the same way as a low ohm PTC resistor, which changes its resistance depending on the heat emitted by the flame. The signals are fed to the control unit where they are processed.

The flame status is monitored by the flame sensor whenever the heater is operating.

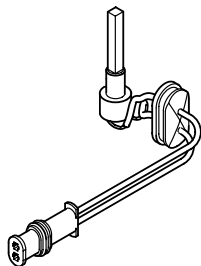

Glow plug / Flame monitor

2.6 Overheating sensor

The overheating sensor measures the temperatures in the rib area of the heat exchanger whenever the heater is operating.

The control unit evaluates the signal and protects the heater from hot air outlet temperatures above 150 °C and surface temperatures above 80 °C by shutting down the combustion process and blowing cold air over the heater. The heater then suffers a fault lock-out and can be restarted by being switched off and on again (see 3.2).

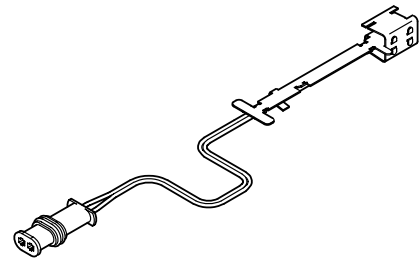

Overheating sensor

2.7 Metering pump

The metering pump is a combined transport, metering and shut-off system for supplying fuel from the vehicle's tank to the heater.

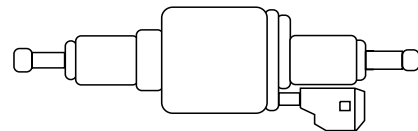

Metering pump DP 30.2/3

3 Function description

3.1 Control element

The control element is designed to switch the heater on and off, adjust the required room temperature (intake temperature between 5 °C and 35 °C) and to reset the heater after a fault.

The integral green LED is designed to act

- as an ON signal (LED permanently lit)
- as a fault signal (LED flashes).

NOTE

ADR operation:

After an operating voltage has been applied by switching the battery isolation switch and control element to "ON" the control unit will be set to the "Fault lock-out" position. Before it can be restarted the control element must be set to "OFF".

3.2 Switch on

Set the control element to the required temperature.

If the hot air temperature is lower than the nominal temperature the heater will start

NOTE

If the temperature of the hot air intake is above the set nominal temperature, only the motor for the hot and combustion air blower will start (control pause). Special feature: The control pause speed is 0 rpm if boat heaters are used.

The function of the flame sensor is checked. If the flame sensor now reports "light", the system will attempt to cool the flame sensor for 60 seconds. If the flame sensor still reports "light" the control unit will suffer a fault lock-out. If another monitored component has suffered a fault, the fault lock-out will take effect without any slow down time.

Start

When the heater is switched on the ON signal light will be lit and the glow plug will be switched on (cycled). The motor for the hot and combustion air blower will be set to approx. 50% of its maximum speed.

After approx. 40 seconds the fuel metering pump will start and the flame formation will begin. To improve the starting quality the metering pump and combustion air blower are started with different frequencies and speeds.

After a further 90 seconds the glow plus will be switched off and the existence of the flame established.

2. Automatic restart

If the flame sensor does not find a flame, the starting procedure will be repeated. The glow plug will be switched on again (cycled). The motor for the hot and combustion air blower will be set to approx. 50% of its maximum speed.

After approx. 40 seconds the fuel metering pump will start and the flame formation will begin.

After a further 50 seconds the glow plus will be switched off and the existence of the flame established.

If the heater has again failed to ignite properly, the it will be shut down using a fault slow down procedure at maximum speed after 180 seconds and will suffer a fault lock-out.

NOTE

After a restart the heater will suffer a fault lock-out. To reset the fault switch the heater off briefly (at least 2 seconds) and then on again.

3.3 Heating mode

Whilst the heater is operating the combustion gases pass through the heat exchanger. During this process the combustion heat is given off to the walls of the heat exchanger, absorbed by the hot air transported by the hot air blower and fed into the interior of the vehicle.

The temperature of the hot air intake is measured by a temperature sensor in the control unit or an external temperature sensor. If the measured temperature is lower than the value set on the control element, the output of the heater is increased to maximum heat output.

To increase the burner service life when it is used continuously the transport capacity of the metering pump is reduced for 10 seconds every 10 minutes.

In addition, heating mode is interrupted every 8 hours in the same way as for a control pause.

3.4 Control mode

In control mode the blower speed and the metering pump delivery rate are dependent on the heat output. The glow plus is switched off.

3.5 Control pause

After the temperature set on the control element has been reached the heat output is reduced. The speed of the heating and combustion air blower and the delivery rate of the metering pump are reduced.

If, at minimum heat output, the intake temperature set on the control element is exceeded, the metering pump is shut down and the combustion process ended. To burn off the flame properly the blower speed falls after 20 seconds to low-fire rate speed and then returns to the initial speed after 15 seconds, after which it falls to the control pause speed in 3 minutes, where it remains for the entire control pause.

The control pause speed on boat heaters is 0.

If the temperature set on the control element is exceeded at the temperature sensor, the heater will restart.

NOTE

Changes to the setting on the control element are implemented by the control unit and heater after a delay.

3.6 Switch off

When the heater is switched off the ON control LED on the control element goes out. If no fuel has been transported or if the heater is in the control pause, the heater is switched off immediately without a slow down time.

If the fuel transport has been started it is ended when the heater is switched off. The heater is switched off using the same method as the transition from control mode to control pause. The heater is then switched off automatically.

NOTE

The heater may be switched on again during the slow down time. In this case the slow down time is completed and the heater is then restarted.

3.7 Heater functions when installed in ADR vehicles

NOTE

Only for Air Top 3500/5000 ST D heaters that are installed in vehicles for transporting hazardous substances (ADR).

If the heater is switched off using the control element the slow down time remains unchanged.

A brief slow down time (max. 40 seconds) is started automatically if

- the vehicle's engine is switched off
- a transport device is started.

After an ADR shut down process the control unit is in the "Fault lock-out" position. Before it can be restarted the control element must be set to "OFF".

3.8 Fault lock-out

Errors on the various heater components and faults in the starting process and in heating mode are identified in the control unit. The heater is switched off and goes into fault lock-out if the following conditions occur:

- No or incorrect start
- Temperature sensor defective
- Overheating sensor interrupt or short circuit
- Overheating sensor installed incorrectly
- Glow plug/Flame monitor interrupt or short circuit
- Blower motor overload or blocked or short circuit or break
- Error in metering pump circuit
- Undervoltage below 10.5 V / 21 V for longer than 20 seconds
- Overvoltage above 16 V / 32 V for longer than 6 seconds
- Control unit defective
- Overheating

The fuel supply is stopped if the heater overheats.

The heater continues to run in the same way as if it is switched off manually.

After it stops the control unit will be set to fault lock-out. The overheating is indicated by the indicator flashing 10 times.

Rectify the cause of the fault.

To reset the fault, switch the heater off briefly (at least 22 seconds) and then on again.

3.8.1 Error monitor

The overheat, incorrect start and flame failure errors are counted and cause the heater to suffer a fault lock-out after an error has occurred the maximum number of times.

The incorrect start counter FSZ is incremented by 1 each time the heater fails to start and decremented by 1 each time it starts correctly, but does not fall below 0. If the incorrect start counter reaches its maximum value of 9 the heater will go into the heater lock-out status HGV.

The error counter SZ is incremented by 1 each error for which there is no separate counter. The error counter is reset to 0 at the start of control mode. If the error counter reaches its maximum value of 9 the heater will go into the heater lock-out status HGV.

The overheating counter ÜHZ is incremented by 1 each time the heater overheats. If the overheating counter reaches its maximum value of 3 the heater will go into the heater lock-out status HGV.

The flame failure counter FAZ is increased by 1 each time the flame fails during heating mode.

The counter is decremented by 1 each time the heater is in control mode.

If the FAZ reaches a value of 3 the heater will go into fault lock-out mode and the permanent flame failure counter FAZP will be incremented by 1. In control mode the permanent flame failure counter FAZP will be decremented by 1. When the heater is burning properly again, the FAZP will return to 0 after a few control cycles. If the permanent flame failure counter exceeds its maximum value of 3, however, the heater will go to permanent heater lock-out status (error code F13).

3.8.2 Reset a fault lock-out

The various fault statuses can be reset as follows.

Fault lock-out:	Switch heater off using the control element and then on again after more than 2 seconds
Heater fault lock-out:	Remove the fuse and reinsert it
Permanent heater fault lock-out:	Delete the error using the PC diagnostic

4 Technical Data

Except where limit values are specified, the technical data listed in the table refer to the usual heater tolerances of $\pm 10\%$ at an ambient temperature of $+20\text{ °C}$ and at the rated voltage and in rated conditions.

Electrical components:

The control unit, combustion air blower, metering pump, timer*, glow plug/flame monitor and control element are designed for 12 V or 24 V.

The voltage is immaterial for the temperature sensor.

* not for ADR

Fuel for Air Top 3500/5000 ST B (petrol):

The fuel specified by the manufacturer must be used.

Fuel for Air Top 3500/5000 ST D (diesel/PME):

The diesel fuel specified by the manufacturer must be used. Class EL heating oil (not L heating oil) may also be used as long as it complies with the normal quality available on the German market pursuant to DIN 51603. We know of no negative influences due to additives.

If fuel is extracted from the vehicle's tank, follow the additive instructions issued by the vehicle manufacturer. If you change to low-temperature fuel, the heater must be operated for approx. 15 minutes so that the fuel system is filled with the new fuel.

The Air Top 3500/5000 ST heater is also licensed for use with PME (bio-diesel), which complies with DIN EN 14214.

The table shows the values for the Air Top 5000 ST heater in brackets.

Heater	Operation	Air Top 3500 (5000) ST B	Air Top 3500 (5000) ST D Air Top 3500 ST D Volume Plus	
Type test permit	EMC heater	e1*72/245*95/54*1221*00 e1*2001/56*0021*00 (3500) e1*2001/56*0020*00 (5000)		
Model		Air heater with evaporation burner		
Heat output	Control range	1.8 – 3.5 (5.0) kW	1.5 – 3.5 (5.0) kW	
Fuel		Petrol	Diesel/PME	
Fuel consumption	Control range	0.17 ... 0.35 0.52 (0.50) kg/h (0.19 ... 0.46 0.66 (0.50) kg/h	0.15 ... 0.35 0.50 (0.50) kg/h (0.18 ... 0.42 0.60 (0.50) kg/h	
Rated voltage		12 V	12 V	24 V
Operating voltage range		10.5 ... 16 V	10.5 ... 16 V	21 ... 32 V
Rated power consumption	Control range	15 – 33 (95) W		
Ambient temperatures: Heater - Operation - Warehouse		-40 °C ... +40 °C -40 °C ... +85 °C		
Metering pump - Operation - Warehouse		-40 °C ... +20 °C -40 °C ... +85 °C		
Control element - Operation - Warehouse		-40 °C ... +75 °C -40 °C ... +85 °C		
Combustion air intake temperature		-40 °C ... +20 °C		
Adjustment range for interior temperature	Control range	+5 °C ... +35 °C		
Delivery rate for hot air at fan speed	against 0.5 mbar	max. 132 (200) m ³ /h at 3600 (5000) rpm		
CO ₂ in exhaust gas (permitted function range)		1.5 kW: 5.0 ... 8.0% 3.5/5.0 kW: 9.0 ... 12.5%	1.5 kW: 5.0 ... 8.0% 3.5/5.0 kW: 9.0 ... 12.5%	
Heater dimensions		Length 423 ± 2 mm Width 148 ± 1 mm Height 162 ± 1 mm		
Weight of heater		5.9 kg		

5 Troubleshooting

5.1 General

This section describes how to identify and deal with errors on the Air Top 3500 ST and Air Top 5000 ST heaters.

If a fault occurs, an error code will be output in the display of the combination timer.

If the heater has a control element, the ON control light will flash.

In addition the heater can be checked using a personal computer (see PC heater diagnostic operating manual).

IMPORTANT

Troubleshooting work demands precise knowledge of the structure and theory of operation of the various components and must be carried out by trained personnel only. If in doubt, refer to sections 2 and 3 for a description of how the functions interact.

NOTE

For ADR mode only:

After an ADR shut-down or an operating voltage has been applied by switching the main vehicle switch and control element to "ON" the control unit will be set to the "Fault lock-out" position. Before it can be restarted the control element must be set to "OFF" or the Immediate heat button pressed on the combination timer.

IMPORTANT

The troubleshooting guide is restricted to the localisation of defective components.

The following potential sources of malfunctions are not taken into account and should always be checked so that they can then be excluded as the cause of the particular fault:

- **Corroded plugs**
- **Loose plug contacts**
- **Poor crimp contacts on plugs**
- **Corroded cables and fuses**
- **Corroded battery terminals**

If you wish to check individual components, the electrical plug connectors on the control unit must be disconnected.

Conduct a function test in the vehicle after rectifying each fault.

5.2 General error symptoms

The following table (Fig. 501) lists the possible error symptoms.

Error symptom	Possible cause	Remedy
Heater cuts out automatically	No combustion after start and restart ON indicator flashes	Switch heater off and then on again
	Flame goes out during operation ON indicator flashes	Switch heater off and then on again
	Heater overheats ON indicator flashes	Check that the hot air system is clear, allow the heater to cool, switch heat off briefly and then on again
	Electrical system voltage too low ON indicator flashes	Charge battery Switch heater off and then on again
Heater produces black smoke	Combustion air and/or exhaust system blocked	Check that the combustion air and exhaust systems are clear

Fig. 501 General error symptoms

5.3 Error symptoms during function

The following table (Fig. 502) lists the possible error symptoms in the order in which they may occur during operation.

In the event of a fault, the error is to be located using this table and rectified. It is important that the error symptom is correctly identified.

If the error symptom is not included in this table or if the

fault is not found under the specific error symptom heading, in an emergency you can contact our technicians on our service hotline (see last page).

NOTE

Every fault is indicated by the flashing LED on the control element after the slow down time has finished. If the other components are OK, a defective control unit may be the cause of all the faults.

Error symptom	Occurrence	Possible causes
No start and no illumination of the LED on the control element	Immediate	Incorrect cabling, defective fuse
No start but LED is lit	Immediate	The heater goes straight to control pause when it is switched on, whereby the control pause speed is 0 rpm for a boat heater.

Fig. 502 Error symptoms during function

Error code	Error (group)	Additional information during PC diagnostic	Remedy
F 07	Metering pump interrupt or short circuit	88 Break or short circuit to +Ub 08 Short circuit to earth	Check cables, replace metering pump Check cables, replace metering pump
F 08	Drive unit (combustion and hot air blower) break or short circuit	89 Break or short circuit to +Ub 09 The switched drive unit cable (combustion and hot air blower) has a short circuit to earth or the drive unit is overloaded 15 Burner motor block guard has tripped 95 Burner motor not turning easily sensor has tripped	Replace drive unit (combustion and hot air blower) Eliminate the cause of the blockage / difficulty in movement Replace drive unit (combustion and hot air blower)
F 09	Glow plug/Flame monitor interrupt or short circuit	8A Glow plug / Flame sensor: Break or short circuit to + Ub 19 Glow circuit: The switched cable of the element has a short circuit to earth	Replace glow plug / flame monitor Replace glow plug / flame monitor
F 10	Overheating	06 The overheating fault lock-out has tripped (heater overheated) 17 Incorrect application or illegal insulation (ÜHS gradient too high)	Find and remove the cause of the overheating NOTE If no other cause can be found for the overheating, the pressure losses caused by the hot air distribution (too many resistance points) are too high or a hot air filter is soiled
F 11	Overheating sensor interrupt or short circuit	AB Overheating sensor circuit break or short circuit to +Ub 1B Overheating circuit: The switched cable of the element has a short circuit to earth	Replace overheating sensor Replace overheating sensor
F 12	Heater fault lock-out	07 The heater fault lock-out has been activated	Remove the fuse and then refit it NOTE The following error has occurred several times: Fault counter more than 3 times Incorrect start counter more than 9 times Overheating counter more than 3 times Flame failure counter more than 2 times
F 13	Permanent heater fault lock-out	87 The permanent heater fault lock-out has been activated	Delete the error with the PC diagnostic NOTE Permanent flame failure counter more than 3 times
F 14	Overheating sensor incorrect position	97 Incorrect position of the overheating system (ÜHS gradient too low)	Position the overheating sensor correctly
F 15	Nominal sensor break	9B Nominal value potentiometer circuit break or short circuit to + Ub	Check cables, replace control element

Fig. 503 Troubleshooting (page 2 of 2)

6 Function tests

6.1 General

This section describes the tests conducted on the heater when it is installed and not installed to verify that it is in working order.

WARNING

The heater must not be operated in enclosed areas such as garages and workshops without an emissions extraction system.

6.2 Settings

6.2.1 Setting the CO₂ content

The CO₂ content in the emissions is set using the adjustment knob on the control element. At a constant blower speed the volume of fuel is controlled by changing the metering pump cycle.

IMPORTANT

The CO₂ measuring instruments must be calibrated. The heater must be switched off.

1. Connect the CO₂ line to minus.
2. Turn the adjustment knob on the control element to the centre setting. The heater will start and go automatically to low-fire rate mode.

NOTE

If the heater can be adjusted the operating indicator will flash as if the control unit has suffered an error.

3. Set the CO₂ value by turning the adjustment knob. Turning it anti-clockwise will reduce the CO₂ value, whilst turning it clockwise will increase it. The measured CO₂ content at low-fire rate (1.5 kW) must be between 5.0% and 8.0%.
4. If the CO₂ value is within this range, disconnect the CO₂ line from minus. This saves the setting.

NOTE

The heater will now run in normal mode again and can be switched off as normal using the control element. The heater is set at the factory to match the fitted combustion air blower.

6.3 Testing individual components

IMPORTANT

For function tests always break the connection between the control unit and the component you wish to test.

6.3.1 Glow plug resistance test

NOTE

The resistance test must be carried out with an ohmmeter suitable for small resistance values.

A resistance test with a simple digital multimeter is too inaccurate to find the precise values. A new glow plug can be measured to act as a reference.

The glow plug should have the following values in the test:

Glow plug:	12 V (red)	24 V (green)
Resistance at 25 °C:	0.280 ... 0.341 W	1.125 ... 1.375 W
Test current:	< 5 mA	< 5 mA

6.3.2 Overheating sensor resistance test

If you conduct this test with a digital multimeter the overheating sensor must have the values shown in the following diagram:

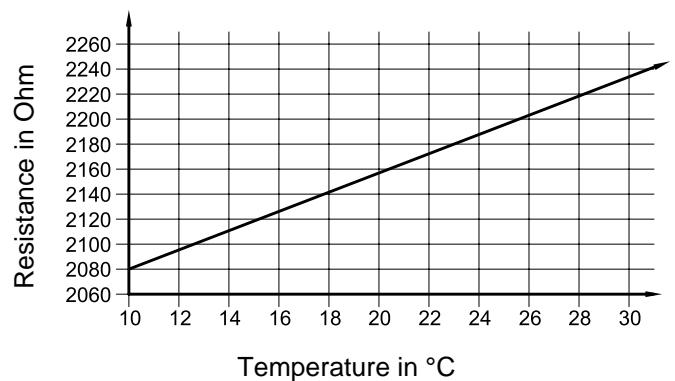

Characteristic resistance values of a PT 2000 overheating system in a temperature range of 10 °C to 30 °C

7 Circuit diagrams

7.1 General

The Air Top 3500 ST and Air Top 5000 ST heaters can be controlled with the control element (nominal value adjuster/switch) or a combination timer.

The circuit diagrams (Fig. 702 to 706) show the possible circuits for 12 and 24 V with

- Control element and vehicle blower
- Combination timer and vehicle blower
- Combination timer and electrical battery isolation switch
- ADR operation with control element
- ADR operation without auxiliary drive with control element

Fig. 701 shows the plug assignment on the control unit.

Fig. 707 shows the schematic connection of the combination timer.

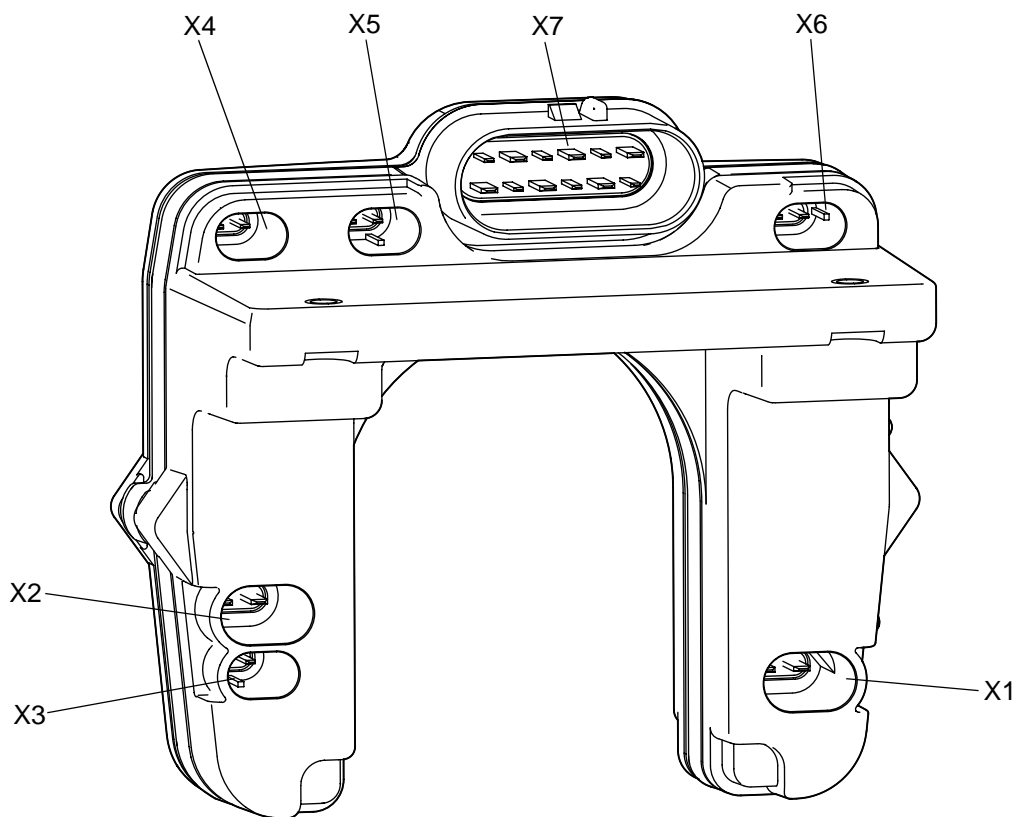

- X1 = Combustion and hot air blower connection
- X2 = Glow plug / Flame sensor connection
- X3 = Overheating sensor connection
- X4 = Metering pump connection
- X5 = External temperature sensor or terminating resistor connection
- X6 = D+ and auxiliary drive unit connection
- X7 = Heater wiring harness connection

Fig. 701 Plug assignment

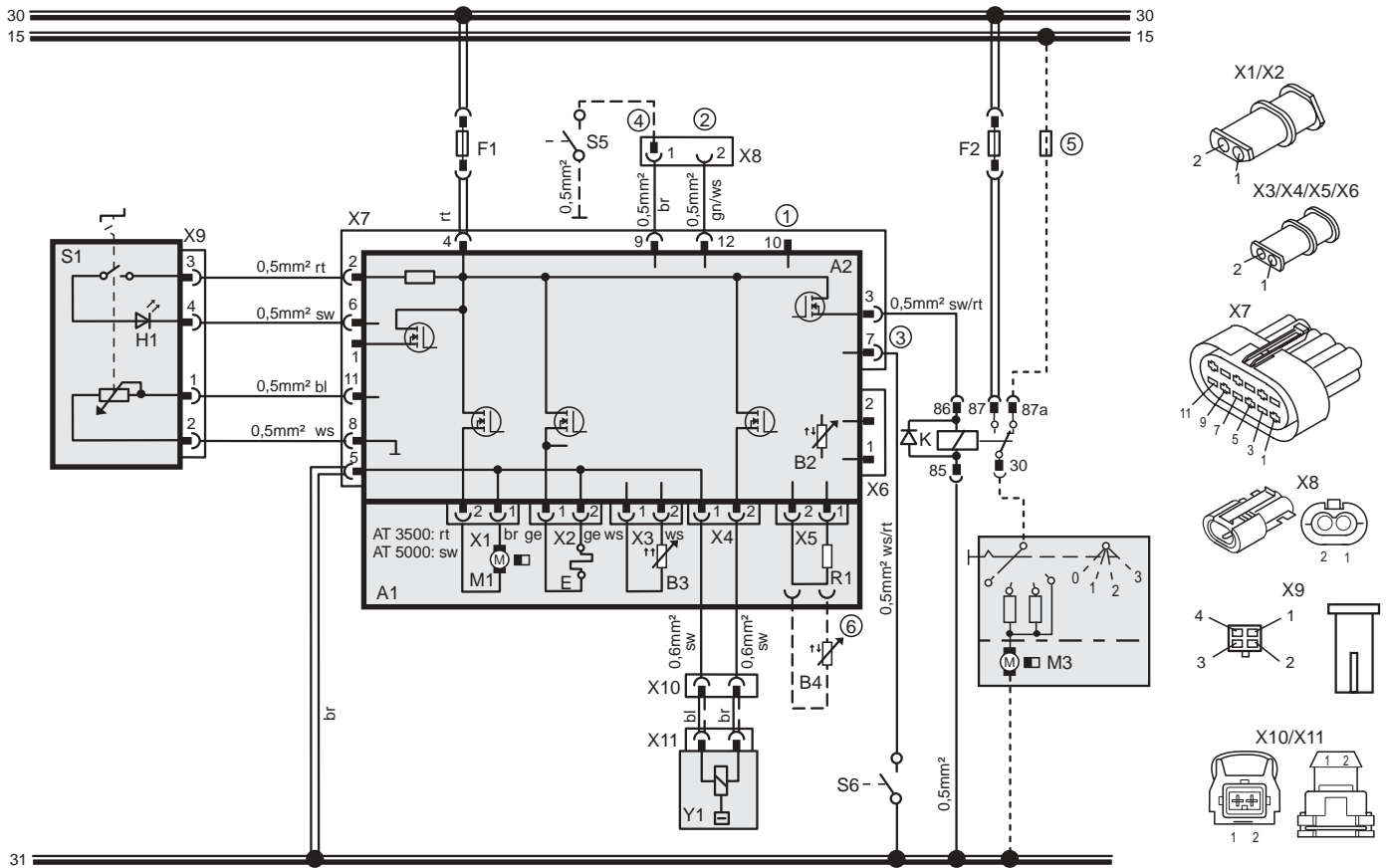

- ① Diagnostic K cable
- ② W bus
- ③ Input pin (pin 7/plug X7), cable colour on wiring harness: white/red:
"Ventilation" (fan speed depends on the position of the control element)
PIN 7 with "Boost" assignment with AT5000ST Boost heater only
- ④ CO₂ setting
- ⑤ Fuse installed in vehicle
- ⑥ If you use an external temperature sensor (B4), the resistor (R1) is replaced by the temperature sensor (B4).

Cable cross-sections		
	< 7,5 m	7,5 15 m
	0,75 mm ²	1,0 mm ²
	0,75 mm ²	1,0 mm ²
	1,0 mm ²	1,5 mm ²
	1,5 mm ²	2,5 mm ²
	2,5 mm ²	4,0 mm ²
	4,0 mm ²	6,0 mm ²

Cable colours	
bl	Blue
br	Brown
ge	Yellow
gn	Green
gr	Grey
or	Orange
rt	Red
sw	Black
vi	Violet
ws	White

Item	Designation	Comment
A1	Heater	Air Top 3500 ST/5000 ST
A2	Control module	
B2	Temperature sensor	Internal
B3	Overheating sensor	Overheating guard
B4	Temperature sensor	External
E	Glow plug / Flame monitor	
F1	Fuse 24V 15A / 12V 20A	Flat fuse SAE J 1284
F2	Fuse 20 A	Flat fuse SAE J 1284
K	Relay with free-wheeling diode	for vehicle fan
H1	LED, green (in item S1)	Indicator
M1	Motor	Combustion and hot air fan
M3	Motor	Vehicle fan
R1	Resistor 620 Ω	With internal temperature sensor only
S1	Control element	Setpoint generator switch
S5	Switch	CO ₂ setting
S6	Switch	Ventilation or boost

Item	Designation	Comment
X1	Plug connector, 2-pin	to item A2
X2	Plug connector, 2-pin	to item A2
X3	Plug connector, 2-pin	to item A2
X4	Plug connector, 2-pin	to item A2
X5	Plug connector, 2-pin	to item A2
X6	Plug connector, 2-pin	to item A2
X7	12-pin plug connection	to item A2
X8	Plug connector, 2-pin	
X9	Plug connector, 4-pin	to item S1
X10	Plug connector, 2-pin	
X11	Plug connector, 2-pin	to item Y1
Y1	Dosing pump	

Fig. 702 System circuit diagram 12V/24V with control element and vehicle blower

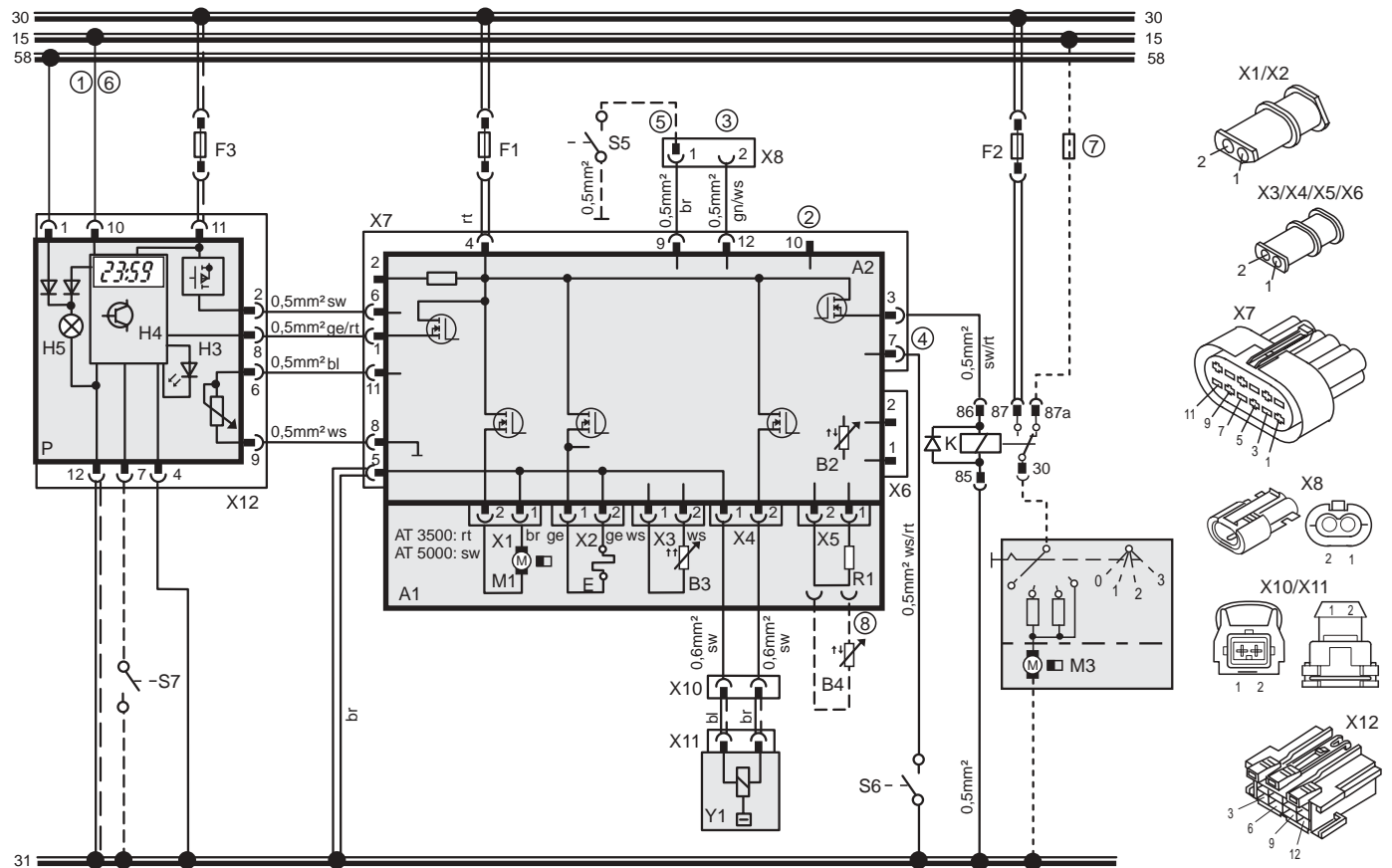

- ① With positive from terminal (15/75) to connection 10:
Permanent operation for immediate heat as long as the ignition is switched on
Without positive at connection 10:
Heating time is variably programmable (10 min to 120 min), default setting 120 min
- ② Diagnostic K cable
- ③ W bus
- ④ Input pin (pin 7/plug X7), cable colour on wiring harness: white/red):
"Ventilation" (fan speed depends on the position of the control element)
PIN 7 with "Boost" assignment with AT5000ST Boost heater only
- ⑤ CO₂ setting
- ⑥ **NOTE**
If the connection is made to terminal 30, permanent heating is possible with the ignition switched off. In this case no connection must be made to terminal 15/75.
- ⑦ Fuse installed in vehicle
- ⑧ If you use an external temperature sensor (B4), the resistor (R1) is replaced by the temperature sensor (B4).

Cable cross-sections		
	< 7,5 m	7,5 15 m
—	0,75 mm ²	1,0 mm ²
- - -	0,75 mm ²	1,0 mm ²
— — —	1,0 mm ²	1,5 mm ²
— — — —	1,5 mm ²	2,5 mm ²
— — — — —	2,5 mm ²	4,0 mm ²
— — — — — —	4,0 mm ²	6,0 mm ²

Cable colours	
bl	Blue
br	Brown
ge	Yellow
gn	Green
gr	Grey
or	Orange
rt	Red
sw	Black
vi	Violet
ws	White

Item	Designation	Comment
A1	Heater	Air Top 3500 ST/5000 ST
A2	Control module	
B2	Temperature sensor	Internal
B3	Overheating sensor	Overheating guard
B4	Temperature sensor	External
E	Glow plug / Flame monitor	
F1	Fuse 24V 15A / 12V 20A	Flat fuse SAE J 1284
F2	Fuse 20 A	Flat fuse SAE J 1284
F3	Fuse max. 15A	Flat fuse SAE J 1284
H3	Red LED (in item P)	Immediate heat button light Ready indicator, Switch-on indicator
H4	Heating symbol in the display (in item P)	Indicator
H5	Light (in item P)	Display and button lights
K	Relay with free-wheeling diode	for vehicle fan
M1	Motor	Combustion and hot air fan
M3	Motor	Vehicle fan

Item	Nomenclature	Remark
P	Combination timer (1531)	Timer and setpoint generator
R1	Resistor 620 Ω	With internal temperature sensor only
S5	Switch	CO ₂ setting
S6	Switch	Ventilation or boost
S7	Momentary-contact switch	Immediate heat button remote control
X1	Plug connector, 2-pin	to item A2
X2	Plug connector, 2-pin	to item A2
X3	Plug connector, 2-pin	to item A2
X4	Plug connector, 2-pin	to item A2
X5	Plug connector, 2-pin	to item A2
X6	Plug connector, 2-pin	to item A2
X7	12-pin plug connection	to item A2
X8	Plug connector, 2-pin	
X10	Plug connector, 2-pin	
X11	Plug connector, 2-pin	to item Y1
X12	12-pin plug connection	to item P
Y1	Dosing pump	

Fig. 703 System circuit diagram 12V/24V with combination timer and vehicle blower

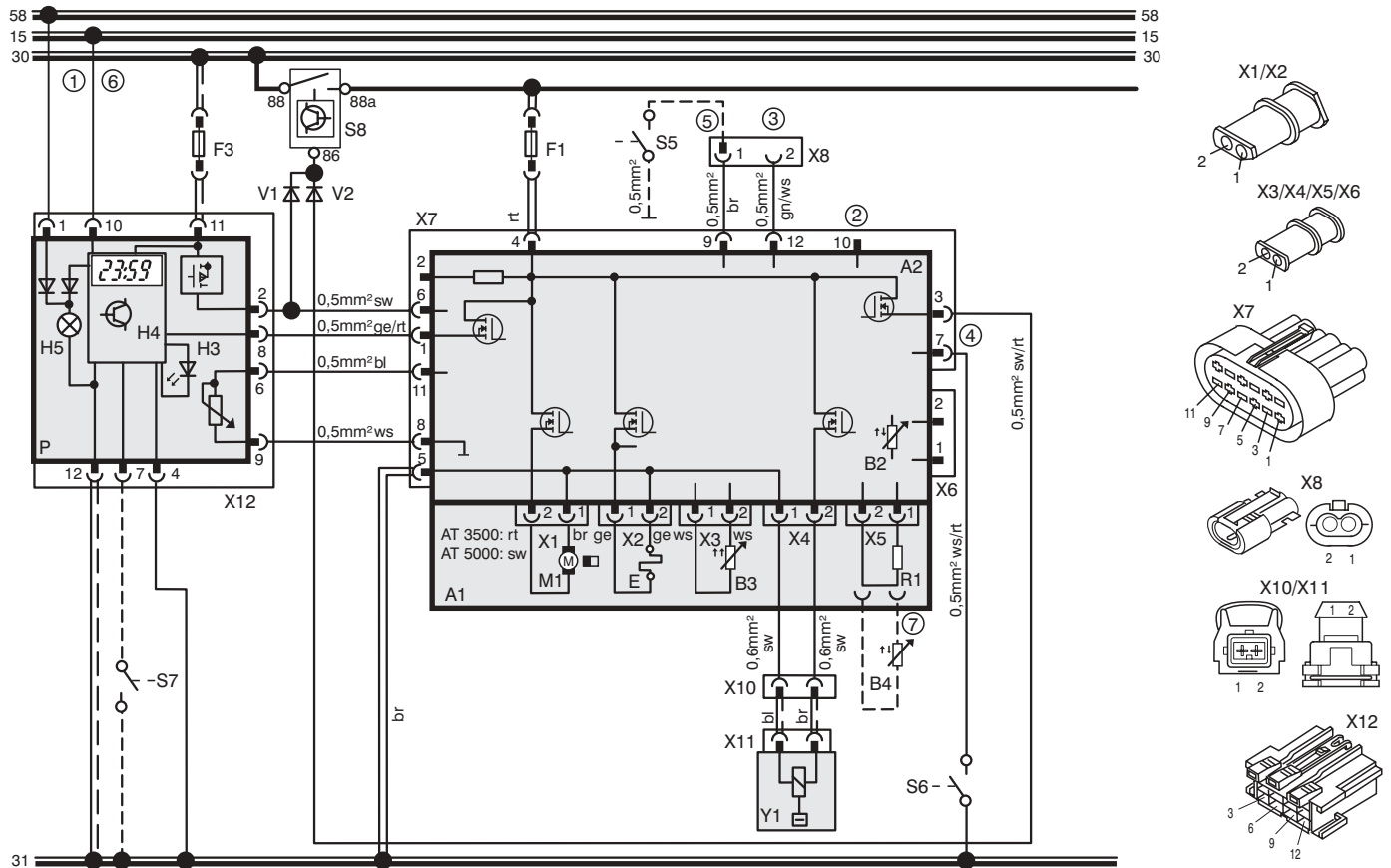

- ① With positive from terminal (15/75) to connection 10:
Permanent operation for immediate heat as long as the ignition is switched on
Without positive at connection 10:
Heating time is variably programmable (10 min to 120 min), default setting 120 min
- ② Diagnostic K cable
- ③ W bus
- ④ Input pin (pin 7/plug X7), cable colour on wiring harness: white/red):
"Ventilation" (fan speed depends on the position of the control element)
PIN 7 with "Boost" assignment with AT5000ST Boost heater only
- ⑤ CO₂ setting
- ⑥ **NOTE**
If the connection is made to terminal 30, permanent heating is possible with the ignition switched off. In this case no connection must be made to terminal 15/75.
- ⑦ If you use an external temperature sensor (B4), the resistor (R1) is replaced by the temperature sensor (B4).

Cable cross-sections		
	< 7,5 m	7,5 15 m
—	0,75 mm ²	1,0 mm ²
- - -	0,75 mm ²	1,0 mm ²
— — —	1,0 mm ²	1,5 mm ²
— — — —	1,5 mm ²	2,5 mm ²
— — — — —	2,5 mm ²	4,0 mm ²
— — — — — —	4,0 mm ²	6,0 mm ²

Cable colours	
bl	Blue
br	Brown
ge	Yellow
gn	Green
gr	Grey
or	Orange
rt	Red
sw	Black
vi	Violet
ws	White

Item	Designation	Comment
A1	Heater	Air Top 3500 ST/5000 ST
A2	Control module	
B2	Temperature sensor	Internal
B3	Overheating sensor	Overheating guard
B4	Temperature sensor	External
E	Glow plug / Flame monitor	
F1	Fuse 24V 15A / 12V 20A	Flat fuse SAE J 1284
F3	Fuse max. 15A	Flat fuse SAE J 1284
H3	Red LED (in item P)	Immediate heat button light Ready indicator, Switch-on indicator
H4	Heating symbol in the display (in item P)	Indicator
H5	Light (in item P)	Display and button lights
M1	Motor	Combustion and hot air fan
P	Combination timer (1531)	Timer and setpoint generator
R1	Resistor 620 Ω	With internal temperature sensor only
S5	Switch	CO ₂ setting

Item	Designation	Comment
S6	Switch	Ventilation or boost
S7	Momentary-contact switch	Immediate heat button remote control
S8	Battery isolation switch	
V1	Diode	
V2	Diode	
X1	Plug connector, 2-pin	to item A2
X2	Plug connector, 2-pin	to item A2
X3	Plug connector, 2-pin	to item A2
X4	Plug connector, 2-pin	to item A2
X5	Plug connector, 2-pin	to item A2
X6	Plug connector, 2-pin	to item A2
X7	12-pin plug connection	to item A2
X8	Plug connector, 2-pin	
X10	Plug connector, 2-pin	
X11	Plug connector, 2-pin	to item Y1
X12	12-pin plug connection	to item P
Y1	Dosing pump	

Fig. 704 System circuit diagram 12V/24V with combination timer and electrical battery isolation switch

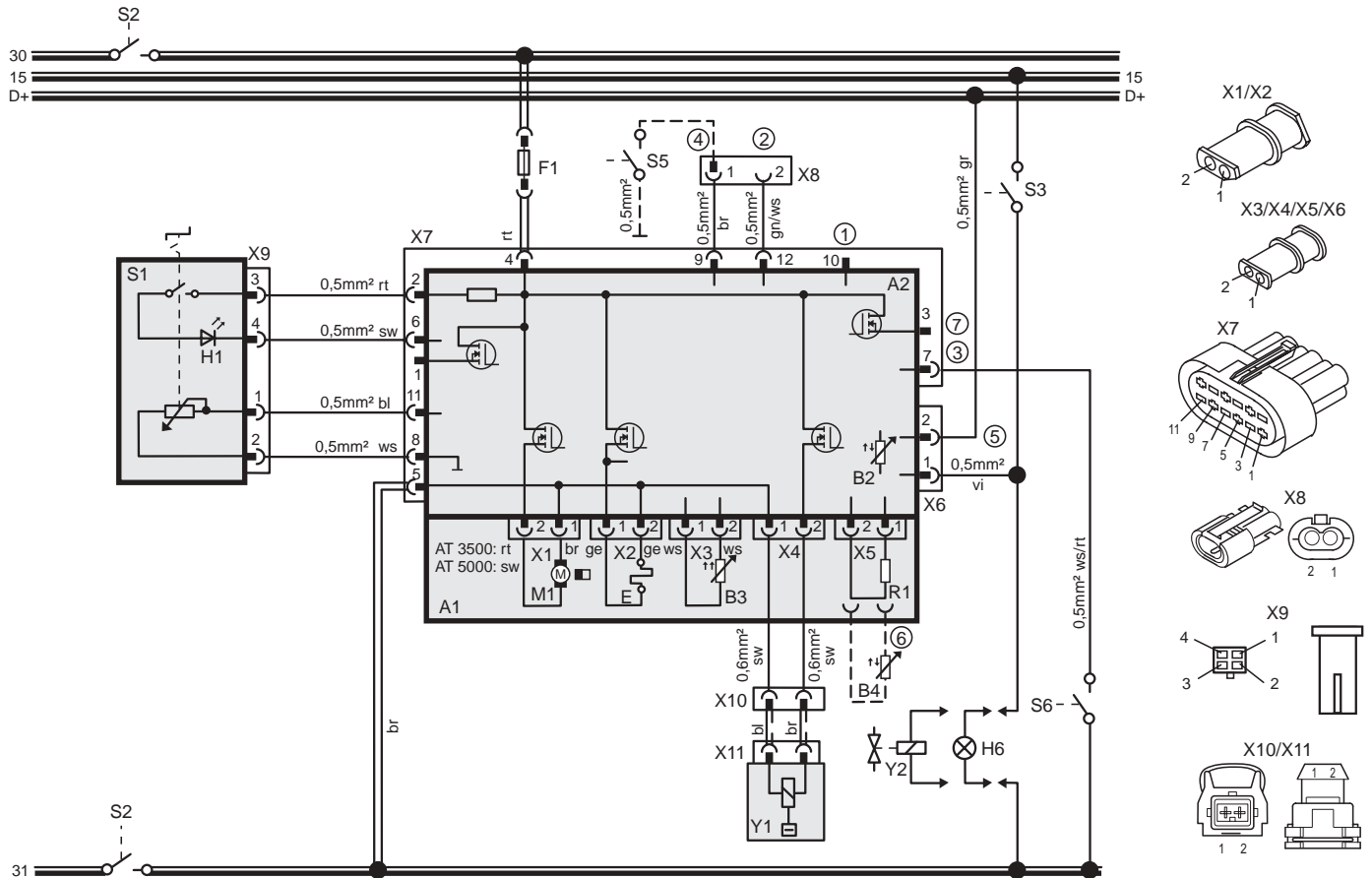

- ① Diagnostic K cable
- ② W bus
- ③ Input pin (pin 7/plug X7), cable colour on wiring harness: white/red:
"Ventilation" (fan speed depends on the position of the control element)
PIN 7 with "Boost" assignment with AT5000ST Boost heater only
- ④ CO₂ setting
- ⑤ **NOTE**
Grey and violet cables required for ADR function
- ⑥ If you use an external temperature sensor (B4), the resistor (R1) is replaced by the temperature sensor (B4).
- ⑦ Holding signal for electrical battery isolation switch
The holding input (if there is one) for the isolation switch (S2) must be connected to the control unit in PIN 3/plug X7.

Cable cross-sections		
	< 7,5 m	7,5 15 m
—	0,75 mm ²	1,0 mm ²
- - -	0,75 mm ²	1,0 mm ²
- - - -	1,0 mm ²	1,5 mm ²
— — —	1,5 mm ²	2,5 mm ²
— — — —	2,5 mm ²	4,0 mm ²
— — — — —	4,0 mm ²	6,0 mm ²

Cable colours	
bl	Blue
br	Brown
ge	Yellow
gn	Green
gr	Grey
or	Orange
rt	Red
sw	Black
vi	Violet
ws	White

Item	Designation	Comment
A1	Heater	Air Top 3500 ST/5000 ST
A2	Control module	
B2	Temperature sensor	Internal
B3	Overheating sensor	Overheating guard
B4	Temperature sensor	External
E	Glow plug / Flame monitor	
F1	Fuse 24V 15A / 12V 20A	Flat fuse SAE J 1284
H1	LED, green (in item S1)	Indicator
H6	Light (at least 1.2 W)	Switch-on indicator pumping device
M1	Motor	Combustion and hot air fan
R1	Resistor 620 Ω	With internal temperature sensor only
S1	Control element	Setpoint generator switch
S2	1 or 2-pin disconnecting switch	Emergency Stop switch
S3	Switch	to or for pumping device
S5	Switch	CO ₂ setting
S6	Switch	Ventilation or boost

Item	Designation	Comment
X1	Plug connector, 2-pin	to item A2
X2	Plug connector, 2-pin	to item A2
X3	Plug connector, 2-pin	to item A2
X4	Plug connector, 2-pin	to item A2
X5	Plug connector, 2-pin	to item A2
X6	Plug connector, 2-pin	to item A2
X7	12-pin plug connection	to item A2
X8	Plug connector, 2-pin	
X9	Plug connector, 4-pin	to item S1
X10	Plug connector, 2-pin	
X11	Plug connector, 2-pin	to item Y1
Y1	Dosing pump	
Y2	Solenoid valve for pumping device	

Fig. 705 System circuit diagram (diesel) 24V ADR mode with control element

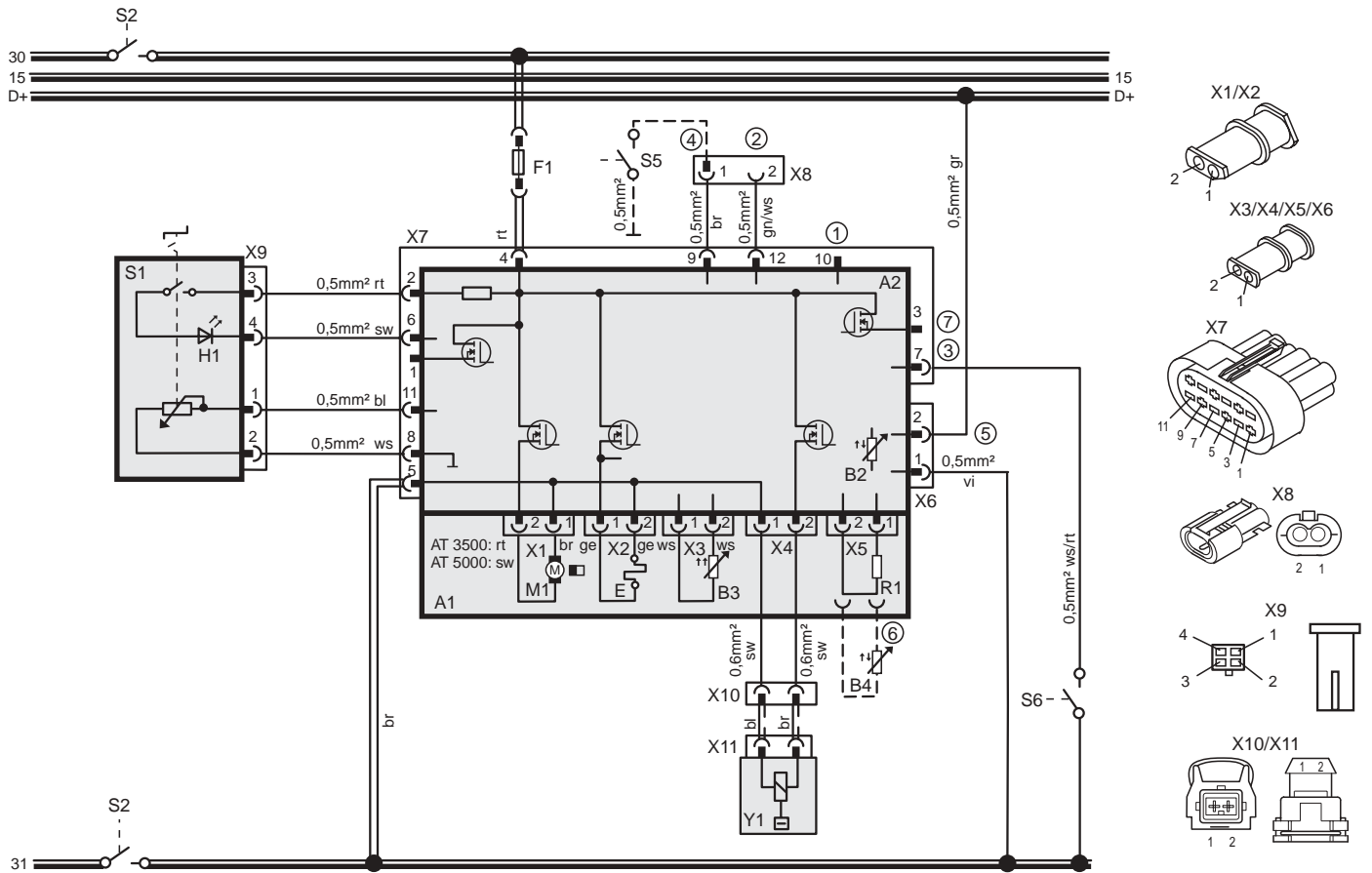

- ① Diagnostic K cable
- ② W bus
- ③ Input pin (pin 7/plug X7), cable colour on wiring harness: white/red): "Ventilation" (fan speed depends on the position of the control element)
- ④ CO₂ setting
- ⑤ **NOTE**
Grey and violet cables required for ADR function
- ⑥ If you use an external temperature sensor (B4), the resistor (R1) is replaced by the temperature sensor (B4).
- ⑦ Holding signal for electrical battery isolation switch
The holding input (if there is one) for the isolation switch (S2) must be connected to the control unit in PIN 3/plug X7.

Cable cross-sections		
	< 7,5 m	7,5 15 m
—	0,75 mm ²	1,0 mm ²
- - -	0,75 mm ²	1,0 mm ²
— — —	1,0 mm ²	1,5 mm ²
— — — —	1,5 mm ²	2,5 mm ²
— — — — —	2,5 mm ²	4,0 mm ²
— — — — — —	4,0 mm ²	6,0 mm ²

Cable colours	
bl	Blue
br	Brown
ge	Yellow
gn	Green
gr	Grey
or	Orange
rt	Red
sw	Black
vi	Violet
ws	White

Item	Designation	Comment
A1	Heater	Air Top 3500 ST/5000 ST
A2	Control module	
B2	Temperature sensor	Internal
B3	Overheating sensor	Overheating guard
B4	Temperature sensor	External
E	Glow plug / Flame monitor	
F1	Fuse 24V 15A / 12V 20A	Flat fuse SAE J 1284
H1	LED, green (in item S1)	Indicator
M1	Motor	Combustion and hot air fan
R1	Resistor 620 Ω	With internal temperature sensor only
S1	Control element	Setpoint generator switch
S2	1 or 2-pin disconnecting switch	Emergency Stop switch
S5	Switch	CO ₂ setting
S6	Switch	Ventilation or boost
X1	Plug connector, 2-pin	to item A2

Item	Designation	Comment
X2	Plug connector, 2-pin	to item A2
X3	Plug connector, 2-pin	to item A2
X4	Plug connector, 2-pin	to item A2
X5	Plug connector, 2-pin	to item A2
X6	Plug connector, 2-pin	to item A2
X7	12-pin plug connection	to item A2
X8	Plug connector, 2-pin	
X9	Plug connector, 4-pin	to item S1
X10	Plug connector, 2-pin	
X11	Plug connector, 2-pin	to item Y1
Y1	Dosing pump	

Fig. 706 System circuit diagram (diesel) 24V ADR mode without auxiliary drive unit with control element

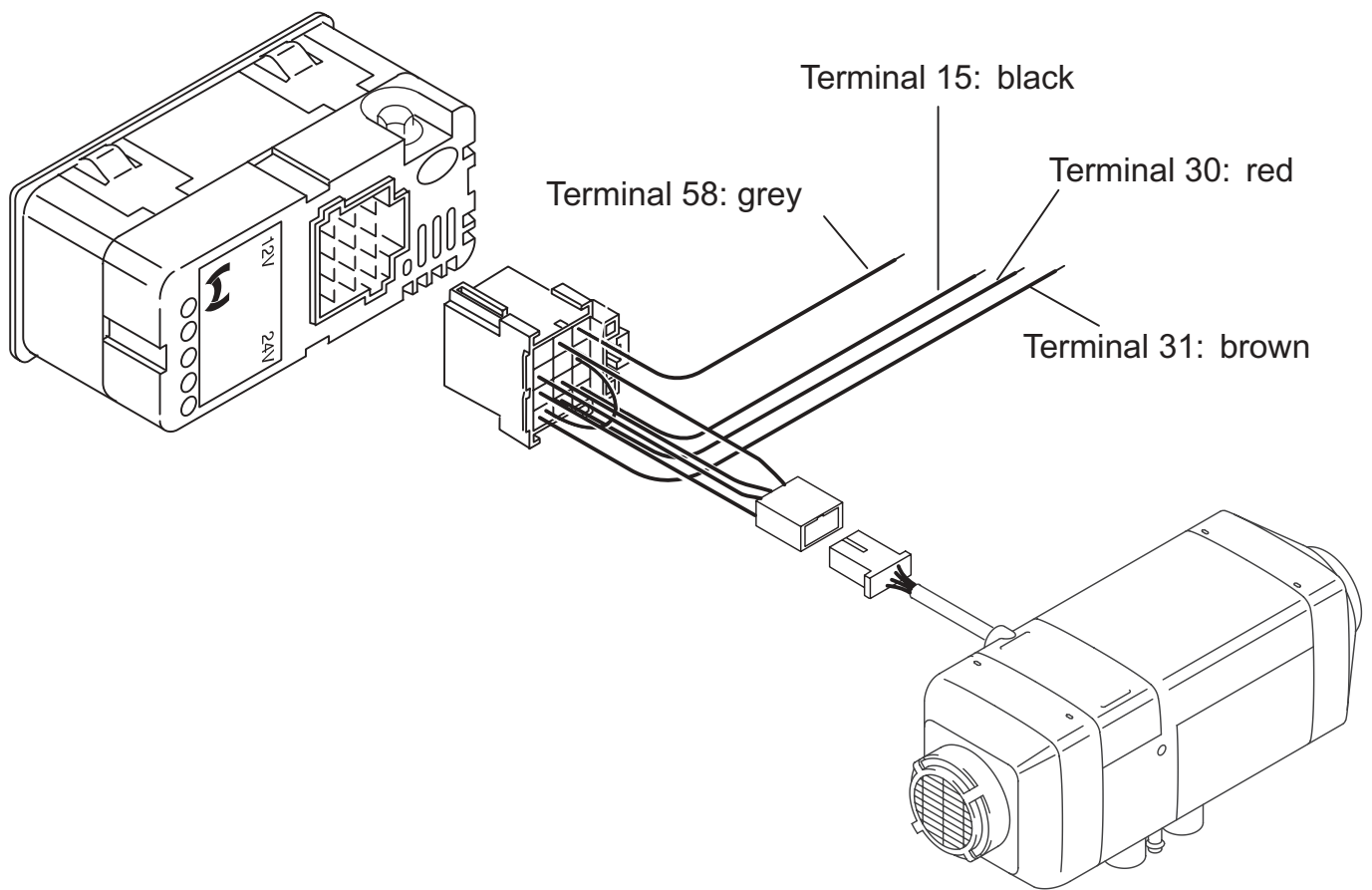

Fig. 707 Schematic connection of the combination timer

8 Servicing work

8.1 General

This section describes the servicing work that can be carried out on the heater when it is installed.

8.2 Work on the heater

Disconnect the main power cable from the vehicle's battery before carrying out any work on the heater. The main battery power must not be disconnected whilst the heater is operating or slowing down as a result of the risk of the heater overheating and the overheating guard thus being tripped. If you wish to carry out extensive repair work on the heater, it may be a good idea to remove it completely.

Refer to the relevant installation instructions and the installation proposal for the heater for the specific vehicle for repairs that necessitate the installation position being changed.

8.3 Work on the vehicle

IMPORTANT

A temperature of 85 °C must not be exceeded in the vicinity of the heater in any circumstances (for example when competing painting work on the vehicle).

8.4 Heater trial

WARNING

The heater must not be operated in enclosed areas such as garages and workshops without an emissions extraction system, even if you use the timer.

IMPORTANT

The heater must not be operated without the cover for the control unit as this will cause it to overheat.

8.5 Servicing work

NOTE

The heater should be operated for approximately 10 minutes every 4 weeks to prevent mechanical parts seizing.

The heater requires no servicing. However, it should be checked at regular intervals, at the latest at start of the heating period (the time after which the heater will be used due to adverse weather conditions) by Webasto-trained personnel.

The following servicing work is to be carried out to maintain the functional reliability of the heater:

- Check the hot air inlet and outlet for dirt and foreign bodies. (Dirty or blocked hot air lines may cause overheating.)
- Clean the exterior of the heater (avoid the ingress of water).
- Check the electrical connections for contact corrosion and to ensure that they are secure.
- Check the exhaust and combustion air lines for signs of damage and to ensure that they are clear.
- Replace the fuel filter if there is one.
- Check the fuel line and filter for leaks.

8.6 Visual inspections and installation instructions

8.6.1 Hot air system

IMPORTANT

The integration of the heater into the vehicle's own air system is not permitted as a result of the high pressure in the vehicle's system.

Inside the control unit there is a temperature sensor, which operates the heater in the appropriate heat output range in conjunction with the control element depending on the intake temperatures and the position of the setpoint generator. The heat output is set so that after the selected interior temperature has been reached quickly, it is then kept at this selected value.

Alternatively the Air Top 3500/5000 ST heaters can be operated with an external temperature sensor (see 9.1.2).

NOTE

Only materials that can permanently withstand temperatures of at least 130 °C may be used for the hot air line.

Maximum pressure drop between the inlet and outlet side of the hot air line:

Air Top 3500 ST	2.0 hPa
Air Top 3500 ST Volume Plus	2.5 hPa
Air Top 5000 ST	2.5 hPa

1 hPa corresponds to 1 mbar corresponds to 10 mm WC

If this value is exceeded the heat output may be reduced as a result of the hot air outlet temperature control.

The heater can be used on the air inlet and outlet side if it is used in an air circulation system. Do not short circuit the current of hot air.

Minimum internal diameter of the main section of hot air line:

- 80 mm for the Air Top 3500 ST
- 90 mm for the Air Top 5000 ST

The hot air hose must be secured at its connection points.

IMPORTANT

In vehicles used to transport people, the air outlet opening is to be directed in such a way that it is at least 20 cm away from all body parts.

The heaters check the internal temperature rise automatically each time they are switched on. If this is above the specified limits, the start is cancelled and error messages F10 is displayed. To ensure that the heater functions stably, the flow resistance of the connected hot air system must be reduced.

If a filter is used for the hot air, it must have the following properties:

- The current of air must not carry any inflammable and/or harmful fibres or particles into the heater or the interior of the vehicle.
- The filter material must be able to withstand temperatures of at least 60 °C
- The filter must be resistant to all the substances that may be drawn in with the hot air (for example moisture, salt, fuel vapours, etc.).
- The resistance of the filter must be taken into consideration when designing the hot air system

8.6.2 Fuel supply

The fuel is taken from the vehicle fuel tank or from a separate fuel tank. The values for the maximum pressure at the fuel extraction point are shown in Fig. 801.

Maximum fuel supply height H (m)	At max. pressure (bar) in fuel line
0.00	0.20
1.00	0.11
2.00	0.03
Maximum fuel intake height S (m)	at max. negative pressure (bar) in the fuel tank
0.00	-0.10
0.50	-0.06
1.00	-0.02

8.6.2.1 Fuel extractor

Vehicles with diesel engines

The fuel must be taken from the vehicle fuel tank or from a separate tank (Fig. 802, 803 or 804). This separate fuel extractor precludes any effect of pressure.

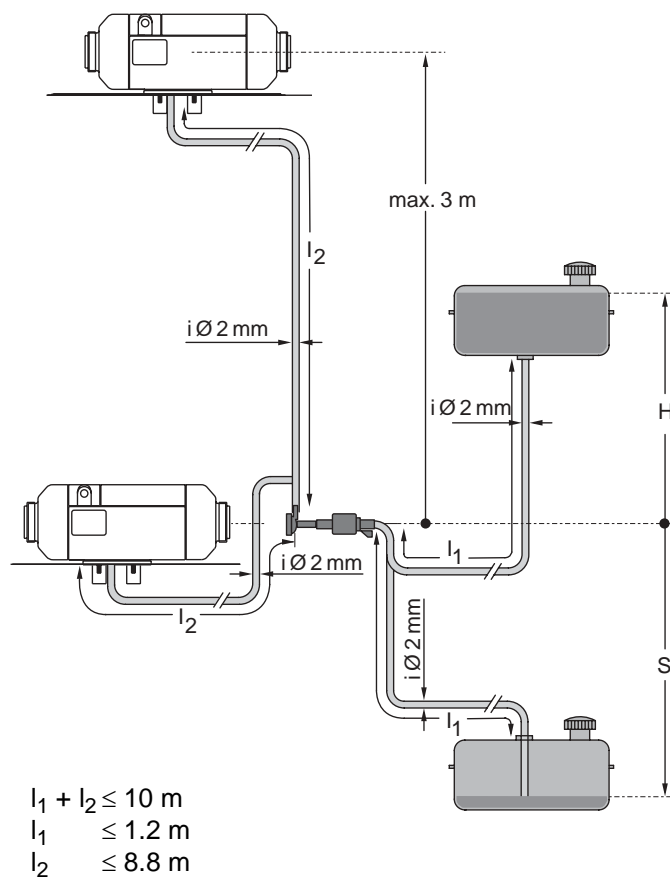

Fig. 801 Fuel supply

Vehicles with carburettor engines

The fuel may only be extracted on cars using the special Webasto fuel extractor (for example Part No. 470 910) as close to the tank as possible. The connection may be made in either the supply or return line, in which case the return line must lead almost to the base of the tank. If this is not the case the return line may be extended.

The fuel extractor must be fitted in such a way that any air or gas bubbles are automatically discharged towards the tank.

The fuel extractor should not be located near the engine, as gas bubbles may form in the lines on account of heat radiated from the engine. This may cause problems during combustion.

Vehicles with injection engines

When installing the heater in a vehicle with fuel injection system, it is important to establish whether the fuel pump is located inside or outside the tank.

If the fuel pump is located inside the tank, fuel can only be extracted from the return line using the Webasto fuel extractor (for example Part No. 470 910), in which case it must be ensured that the return line continues almost to the bottom of the tank. If this is not the case Webasto fuel extractor (see Fig. 802, 803 or 804) may be used.

If the fuel pump is installed outside the tank, the fuel connection may also be made between the tank and the fuel pump, again using only the Webasto fuel extractor (for example Part No. 470 910).

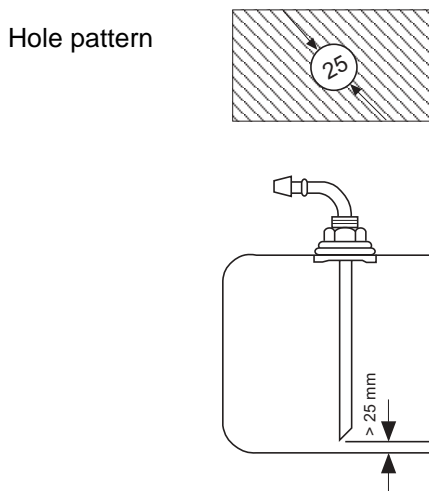

NOTE

Only use a tank extractor with metal fuel tanks

Fig. 802 Webasto fuel extractor

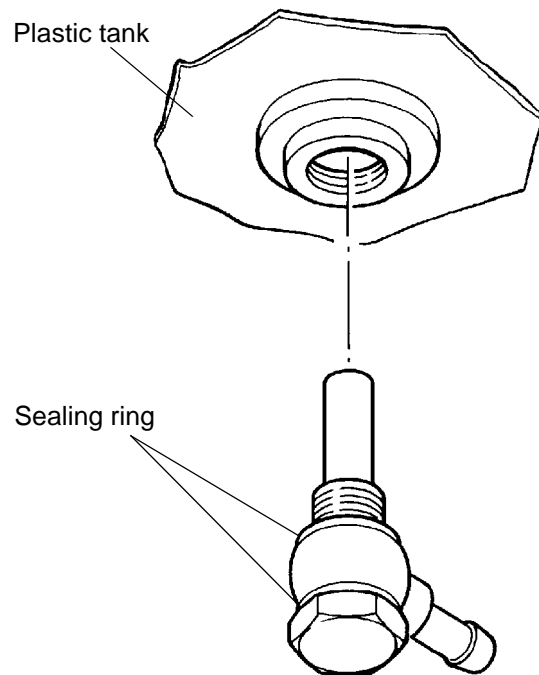
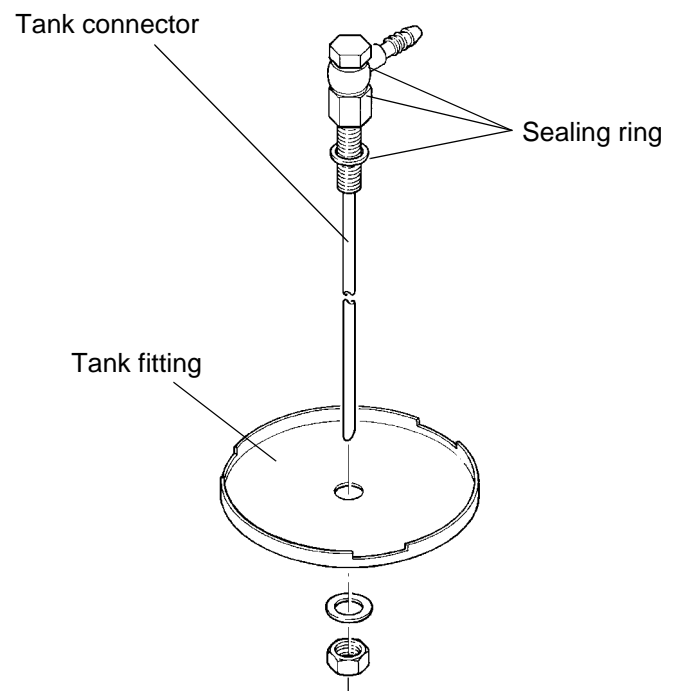

Fig. 803 Fuel extractor from the plastic tank (extraction through tank drain screw)



NOTE

The fitting must be made from metal!

Fig. 804 Fuel extractor from the plastic tank (extraction through tank fitting)

8.6.2.2 Fuel lines

Only steel, copper and plastic lines of plasticised, light and temperature-stabilised PA11 or PA12 (for example Mecanyl RWTL) pursuant to DIN 73378 may be used for the fuel lines.

Since the lines cannot always be routed with a constant rising gradient, the internal diameter must not be allowed to exceed a certain size. Air or gas bubbles will accumulate in lines with an internal diameter of more than 4 mm and these will cause malfunctions if the lines sag or are routed downwards.

The diameters specified in Fig. 801 will ensure that bubbles do not form.

The lines should not be routed downwards from the metering pump to the heater.

Unsupported fuel lines must be secured to prevent them sagging. They must be installed in such a way that they cannot be damaged by flying road chippings and **high temperatures** (exhaust pipe).

The fuel lines must be secure at the connections using hose clips to prevent their slipping.

Connecting two pipes with a hose

The correct procedure for connecting fuel lines with hosing is shown in Fig. 805.

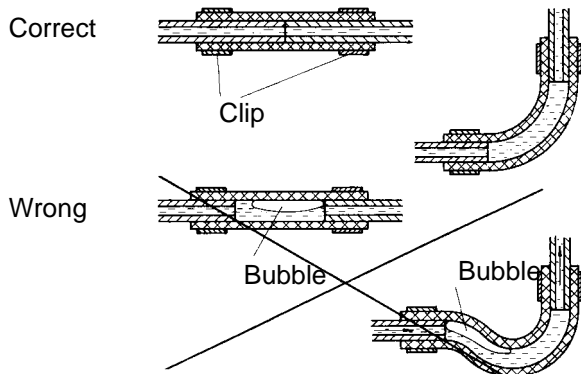
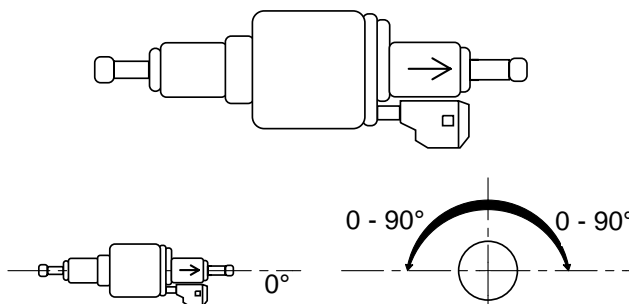

Fig. 805 Pipe/Hose connections

8.6.3 Metering pump

The metering pump is a combined delivery, metering and shut-off system and is subject to certain installation criteria (Fig. 801 and 806).



12 V and 24 V – diesel DP 30
Horizontal installation only

Fig. 806 Metering pump, installation position

8.6.3.1 Installation location

It is advisable to install the metering pump in a cool place. The maximum ambient temperature must not exceed +20 °C at any time during operation. The metering pump and fuel lines must not be installed within range of the radiated heat from hot vehicle parts. A heat shield must be used if necessary.

8.6.3.2 Installation and attachment

The metering pump must be secured with a vibration-damping mounting. Its installation position is limited as shown in Fig. 806 in order to ensure effective automatic bleeding. As a result of the risk of corrosion, only genuine Webasto parts may be used for the plug connections between the metering pump and the metering pump wiring harness.

8.6.4 Fuel filter

Only a Webasto filter, Part No. 487 171, may be used if the fuel is expected to be contaminated. Install vertically if possible, however at most horizontally (check flow direction).

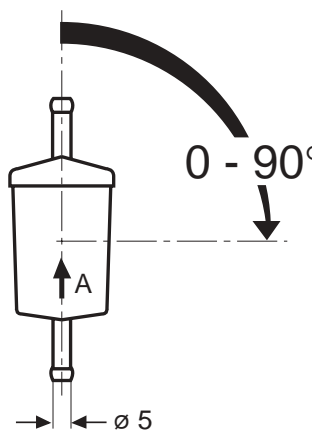

Fig. 807 Fuel filter

8.6.5 Combustion air supply

Under no circumstances may the combustion air be taken from areas occupied by people. The combustion air intake opening must not point in the direction of travel. It must be located so that it cannot become clogged with dirt.

NOTE

The combustion air must be extracted using a combustion air line from a position that is as cool as possible and protected from splashing water for petrol heaters. If the heater is in a sealed installation box, the combustion air must be drawn in from the outside and the emissions fed to the outside. Pipe passage holes must be made in such a way as to ensure that the ingress of exhaust fumes into the interior of the vehicle should not occur. If dirty combustion air is expected, a combustion air filter may be fitted (Air Top 3500/5000 ST D only). An intake silencer must be used for an intake hose length of < 0.6 m.

8.6.6 Exhaust line

Rigid pipes of unalloyed or alloyed steel with a minimum wall thickness of 1.0 mm or flexible piping of alloyed steel only must be used as exhaust line.

The exhaust pipe must be secured to the heater and exhaust silencer with a pipe clip, Part No. 20 965A.

The exhaust silencer (Fig, 808) should ideally be installed near the heater.

The flow direction is arbitrary.

The heater may also be operated without a silencer.

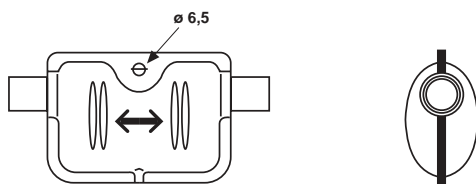

Fig. 808 Exhaust silencer

8.6.7 Combustion air inlet and exhaust lines

NOTE

To prevent damaging the metering pump cable, exhaust line must not be used to extend the combustion air supply line.

Length of the combustion air intake and exhaust lines:

With silencer:	max. 2.0 m
Without silencer:	max. 5.0 m

Both lines are to be installed falling away from the heater. If this is not possible, a condensate drain hole with a diameter of 4 mm must be made at its lowest point or a connection element with a condensate drain used.

Internal diameter of the lines:

Combustion air line:	25 mm
Exhaust line:	24 mm

NOTE

If the exhaust line is 2 m or more, insulated exhaust lines must be used (to prevent the temperature falling below the dew point).

Minimum bending radius:	50 mm
-------------------------	-------

Total bends:

Combustion air line:	max. 270°
----------------------	-----------

Exhaust line:	max. 270°
---------------	-----------

An attachment is required no further than 150 mm from the end of the exhaust pipe to ensure that the angle of $90^\circ \pm 10^\circ$ is achieved.

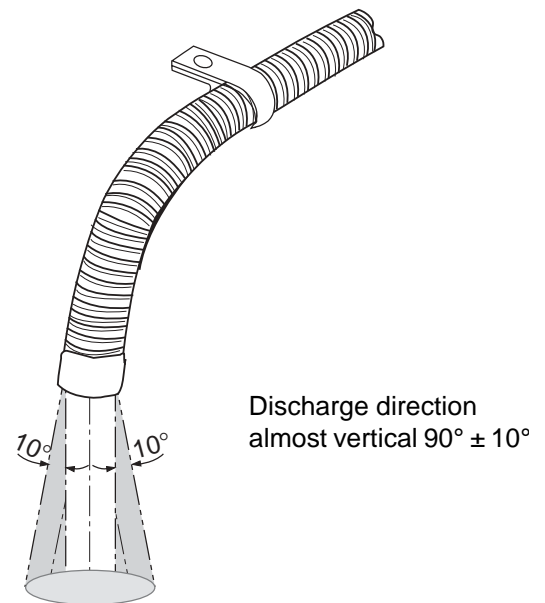

Fig. 809 Exhaust pipe mouth, installation position

WARNING

If the exhaust pipe mouth is positioned is other than as shown in the Fig. 809 it will pose a fire risk.

8.6.8 Electrical connections

8.6.8.1 Heater connection, control element

The electrical connection is to be made as shown in the appropriate circuit diagram (see section 7). To connect the wiring harness, remove the cover (see 9.2.1.1) on the heater and connect the wiring harness plug to the control unit.

Before using the heater for the first time fit the cover to prevent the illegal escape of hot air (heater overheating).

The wiring harness can be fed out of the left or right side of the heater.

8.6.8.2 Supply voltage connection

Ideally from the vehicle's central electrical system.

An additional blade terminal fuse holder is to be fitted to protect the heater (supplied with the heater). The fuse holder may only be installed in the interior of the vehicle.

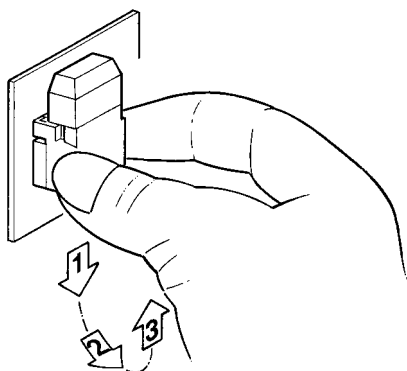

Fig. 810 Remove the fastening plate on the fuse holder

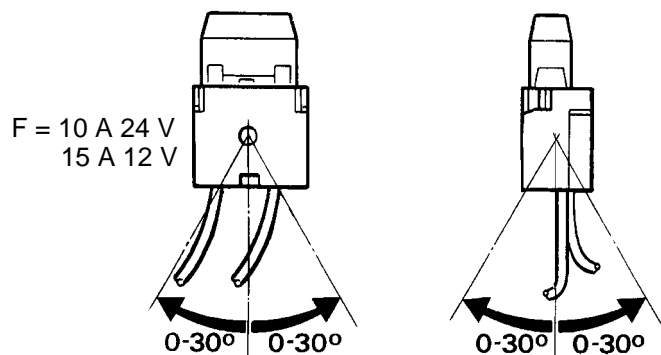

Fig. 811 Fuse holder, installation position

8.6.8.3 Control element connection

The wiring harness is prepared for connection to the control element (adjuster). Simply pull on connector housing to disconnect the connector (Fig. 813).

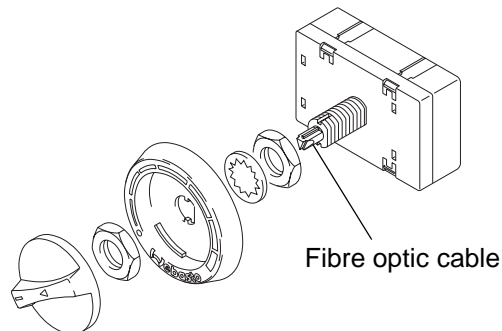

Fig. 812 Control element

NOTE

The fibre optic cable must be in contact with the rotary knob.

NOTE

The connector housing can be locked (self-locking action) by simply pulling on the wiring harness.

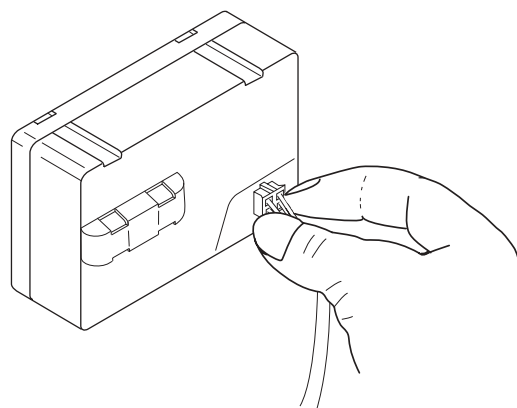
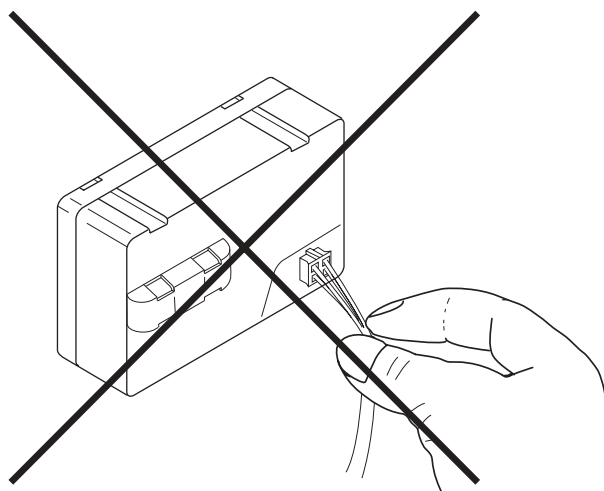
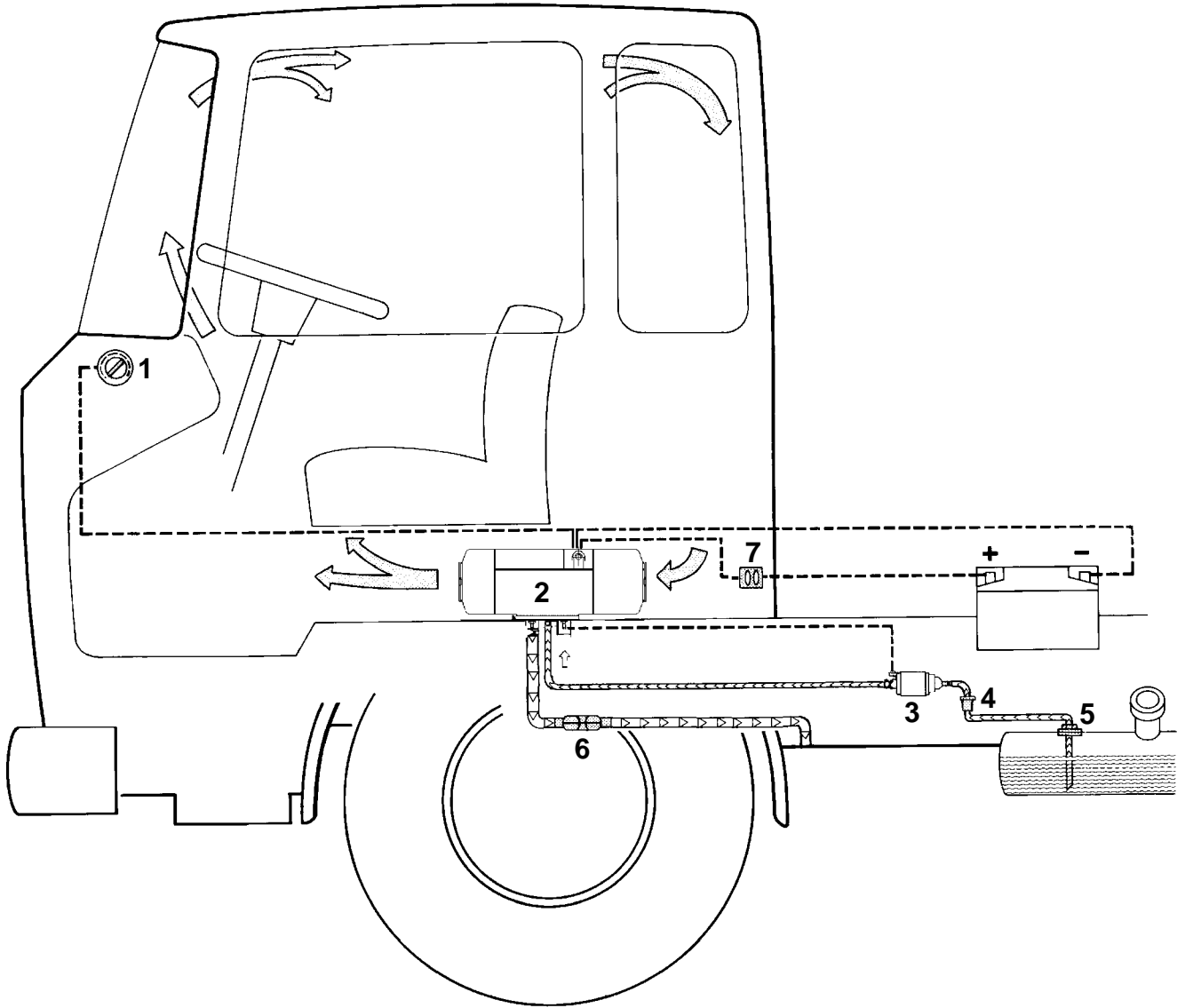

Fig. 813 Disconnect the plug



- 1 Control element
- 2 Heater
- 3 Metering pump
- 4 Fuel filter (accessory)
- 5 Tank connector
- 6 Exhaust silencer
- 7 Fuse

Fig. 814 Specimen installation for heater in an air circulation system

8.7 Removal and installation**IMPORTANT**

When the heater is installed it must not be dismantled.

8.7.1 Heater, removal and installation**8.7.1.1 Removal**

1. Disconnect the battery.
2. Pull the cover off the top shell as described in 9.2.1.1.
3. Disconnect the wiring harness plug from the control unit.
4. Disconnect the cable to the metering pump at the disconnection point.
5. If necessary disconnect the hot air hose or hoses connection.
6. Disconnect the connection for the combustion air inlet on the heater.
7. Disconnect the connections for the combustion air inlet and exhaust outlet on the heater.
8. Remove four nuts and locking washers from the heater.
9. Remove the heater and discard the seal on the exhaust outlet.

8.7.1.2 Installation

1. Place the heater with a new seal on the exhaust outlet in the installation position and secure it with 4 nuts and locking washers (use only genuine Webasto nuts).
2. Tighten the nuts to 6 +1 Nm.
3. Secure the connection for the combustion air inlet on the heater.
4. Secure the connections for the combustion air inlet and exhaust outlet on the heater.
5. Connect the metering pump cable to the metering pump wiring harness.
6. Connect the wiring harness plug to socket X7 on the control unit.
7. Fit the cover as described in 9.2.2.5 and secure it.
8. If necessary fit the hot air hose or hoses and secure them.
9. Connect the battery.
10. Bleed the fuel supply system.

8.8 Start-up

After you have installed the heater, bleed the fuel supply system carefully.

NOTE

As a result of the low fuel consumption the heater must be switched on several times to fill the fuel line.

Conduct a trial of the heater to check all the connections for leaks and to ensure that they are secure. If the heater suffers a fault during operation, the fault must be located and remedied.

9 Repair

9.1 General

This section describes the repair work that may be carried out on the Air Top 3500/5000 ST heater after it has been removed from the vehicle.

Any further dismantling will invalidate the warranty. Only use the spare parts from the appropriate spare parts kits for assembling the heater.

9.1.1 Work on stripped down components

IMPORTANT

All sealing elements between the stripped down components and the seal on the exhaust outlet must always be discarded and replaced.

9.1.1.1 Cleaning

- Clean all stripped down components with benzene and then dry them with compressed air.
- Remove all seal residue on the components in full carefully using a suitable tool.

9.1.1.2 Visual inspection

- Check all components for damage (cracks, deformation, wear, etc.) and fit new ones if necessary.
- Inspect the plugs and cables for corrosion, loose contacts, crimping faults, etc. and repair them if necessary.
- Check plug strips for signs of corrosion and contacts to ensure they are secure. Repair them if necessary.

9.1.2 Carrying out modifications

NOTE

The constant development of our heaters is aimed at optimising them so as to prevent failures and malfunctions.

Generally it is possible to modify heaters that are already in use. We can supply the appropriate modification kits for this purpose.

The following describes modifications that can be carried out without any great effort during standard repair work:

- Installation of an external temperature sensor for better temperature control (see 9.1.2.1).

9.1.2.1 Installation of an external temperature sensor

General

The Air Top 3500 ST or Air Top 5000 ST heater can control the required temperature perfectly if its temperature sensor is exposed to the air temperature of the main area of the vehicle. In certain circumstances, this is not always possible using the temperature sensor integrated in the control unit due to the installation circumstances. In this case perfect temperature control can be ensured using an external temperature sensor fitted in the appropriate area.

Method

1. Select a suitable position for an external temperature sensor.

NOTE

- The temperature sensor should not be in the direct line of hot air and not close to heat sources (for example the vehicle's own heating system).
 - The sensor is to be installed at medium height in the vehicle cabin on surfaces that are as vertical as possible.
 - The installation site should not be exposed to direct sunlight.
 - Do not install the temperature sensor behind curtains or the like.
2. Remove the cover and disconnect the terminating resistor (5, Fig. 902) from the control unit (plug X5).
 3. Install the external temperature sensor and route the cable to the heater.
 4. Connect the plug on the external temperature to socket X5 on the control unit and fit the cover.
 5. Conduct a trial and check the control properties.

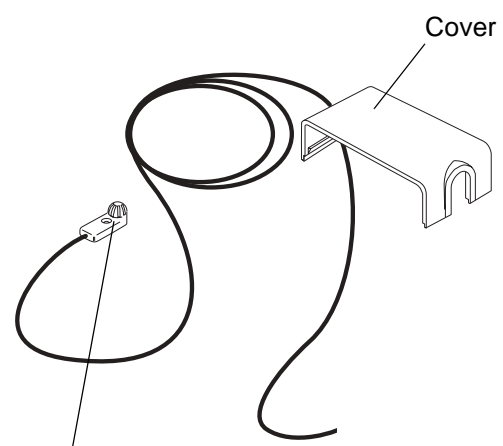

External temperature sensor

9.2 Dismantling and assembling

9.2.1 Remove the casing parts

9.2.1.1 Cover for electrical connection

The cover (1, Fig. 901) can be levered off using a blunt blade in the areas marked (X).

9.2.1.2 Grate for hot air inlet and outlet

The grate (6, Fig. 901) can be released from its mounting by twisting it and then pulled off forwards.

9.2.1.3 Covers for hot air inlet and outlet

Both covers (3 and 5, Fig. 901) can be released from their mountings and removed by pressing the four detents at the top and bottom using a suitable tool.

9.2.1.4 Top shell

NOTE

The covers for the hot air inlet and outlet must have been removed.

The top shell (2, Fig. 901) can be raised after the covers for the hot air inlet and outlet have been removed.

9.2.1.5 Bottom shell

Remove the seal from the exhaust outlet.

NOTE

The insulating mat (7, Fig. 901) is only fixed on the heater by the casing parts.

By pulling the bottom shell (4) on both sides gently around areas (Y), you can release the fixing and the shell can be taken off the motor casing. Take the insulating mat off (7) at the same time.

9.2.2 Fit the casing parts

9.2.2.1 Bottom shell

IMPORTANT

To ensure that the heater and the overheating sensor work perfectly, please note the following when fitting the casing:

- Position the insulating mat (7, Fig. 901) so that half of the width of the mat is under the shells (4 and 2) or under the cover for the hot air outlet (3).
- When you fit the top shell (2) ensure that the insulating mat is secure.
- If the insulating mats are heavily pressed or old, replace them

1. Ensure that the insulating mat (7) is properly positioned on the heat exchanger.

IMPORTANT

When you fit the bottom shell (4), spread it slightly so that the spacers on the overheating sensor (9, Fig. 902) are not damaged.

2. Expand the bottom shell (4, Fig. 901) slightly at the side and fit it to the heater from underneath until the securing pins on the heater engage in the holes in the shell.
3. Fit a new seal on the exhaust outlet.

9.2.2.2 Top shell

1. Place the top shell (2, Fig. 901) on the heater and secure it in the grooves in the bottom shell.

9.2.2.3 Cover for hot air inlet and outlet

NOTE

The covers for the hot air inlet and outlet are different. Fit the cover with the larger opening at the front on the hot air blower.

1. Push on the covers (3 and 5, Fig. 901) until the four securing holes engage properly in the detents on the bottom and top covers.

9.2.2.4 Grate for hot air inlet and outlet

1. Fit the grates (6, Fig. 901) on the covers for the hot air inlet and outlet and twist them to secure them.

9.2.2.5 Cover for electrical connection

NOTE

The wiring harness is to be taken out of the left or right of the heater to suit the installation situation.

1. Fit the cover (1, Fig. 901) until it audibly engages in the top cover.

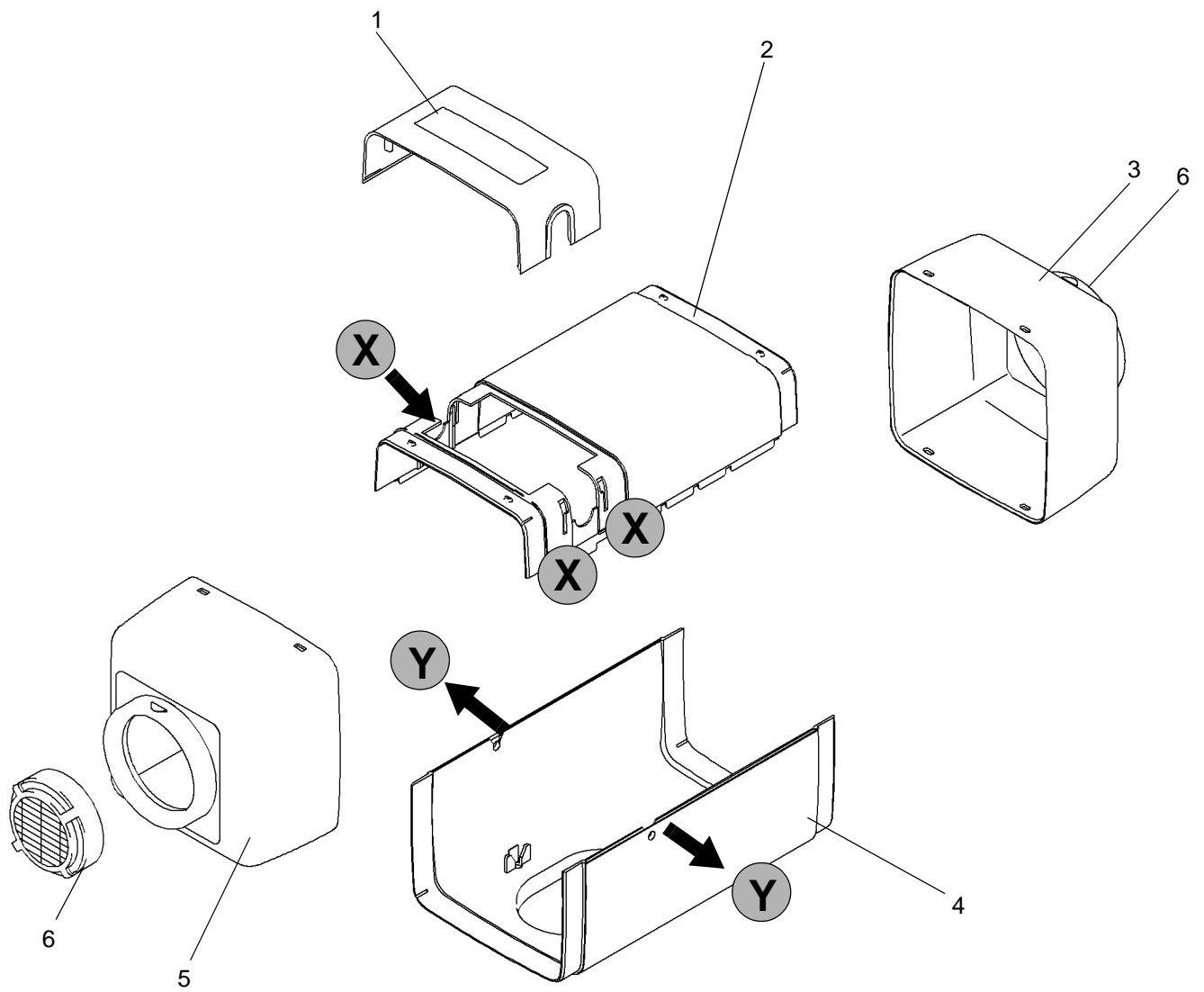

- 1 Cover, electrical connection
- 2 Top shell
- 3 Cover, hot air outlet
- 4 Bottom shell
- 5 Cover, hot air inlet
- 6 Grate
- 7 Insulating mat

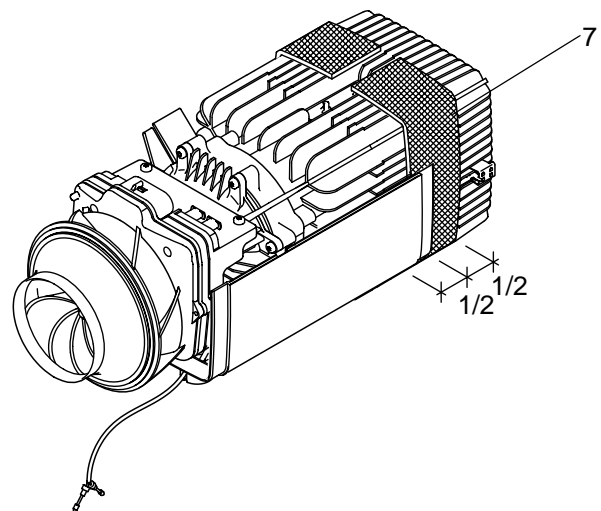

Fig. 901 Remove / Fit the casing parts

9.2.3 Change the control unit**9.2.3.1 Removal**

1. Remove the heater (see 8.7.1.1).
2. Remove the casing parts (see 9.2.1).
3. Disconnect the plug connections on the control unit (3, Fig. 902).
4. Remove the screws (4).
5. Slide the control unit (3) towards the hot air blower and remove it upwards.
6. Complete the work on stripped down components (see 9.1.1).

NOTE

Do not carry out any repair work to the control unit.

9.2.3.2 Installation

1. Insert the control unit (3, Fig. 902) on the combustion and hot air blower (1), push it towards the blower casing and secure it with screws (4).
2. Tighten the screws to 3.0 ± 0.3 Nm.
3. Connect the plug connections on the control unit as shown in Fig. 701.
4. Fit the casing parts (see 9.2.2).
5. Install the heater (see 8.7.1.2).
6. Check the CO₂ setting and adjust it if necessary (see 6.2).

9.2.4 Change the overheating sensor**9.2.4.1 Removal**

1. Remove the heater (see 8.7.1.1).
2. Remove the casing parts (see 9.2.1).
3. Disconnect plug connection X3 on the control unit (3, Fig. 902).
4. Lever the overheating sensor (9) out of the heat exchanger's ribs using a suitable tool (see Detail A).

IMPORTANT

Do not pull the cables.

5. Remove the overheating sensor (9).

9.2.4.2 Installation

1. Measure the resistance of the overheating sensor (9, Fig. 902) (see 6.3.2).
2. Position the overheating sensor (9) and press it into place by hand.
3. Ensure that the overheating sensor is correctly positioned in the heat exchanger (7).
4. Connect plug connection X3 to the control unit (3).
5. Fit the casing parts (see 9.2.2).
6. Install the heater (see 8.7.1.2).

9.2.5 Change the combustion and hot air blower (drive unit)**IMPORTANT**

Replace the drive unit (1, Fig. 902) only with a drive unit with the same rating data and the same Part No.

NOTE

The drive unit (combustion and hot air blower) can only be replaced in full. It cannot be repaired.

9.2.5.1 Removal

1. Remove the heater (see 8.7.1.1).
2. Remove the casing parts (see 9.2.1).
3. Remove the control unit (see 9.2.3.1).
4. Remove the screws (2).
5. Remove the combustion and hot air blower (1) forwards.
6. Remove and discard the flat seal (6).
7. Complete the work on stripped down components (see 9.1.1).

9.2.5.2 Installation

1. Ensure that the sealing surfaces on the combustion and hot air blower (1, Fig. 902) and on the heat exchanger (7) are not damaged.
2. Fit a new flat seal (6) on the flange of the combustion and hot air blower (1).
3. Position the combustion and hot air blower (1) into the assembly position and secure it with screws (2).
4. Tighten the screws to 6.0 ± 0.6 Nm.
5. Fit the control unit (see 9.2.3.2).
6. Fit the casing parts (see 9.2.2).
7. Install the heater (see 8.7.1.2).
8. Check the CO₂ setting and adjust it if necessary (see 6.2).

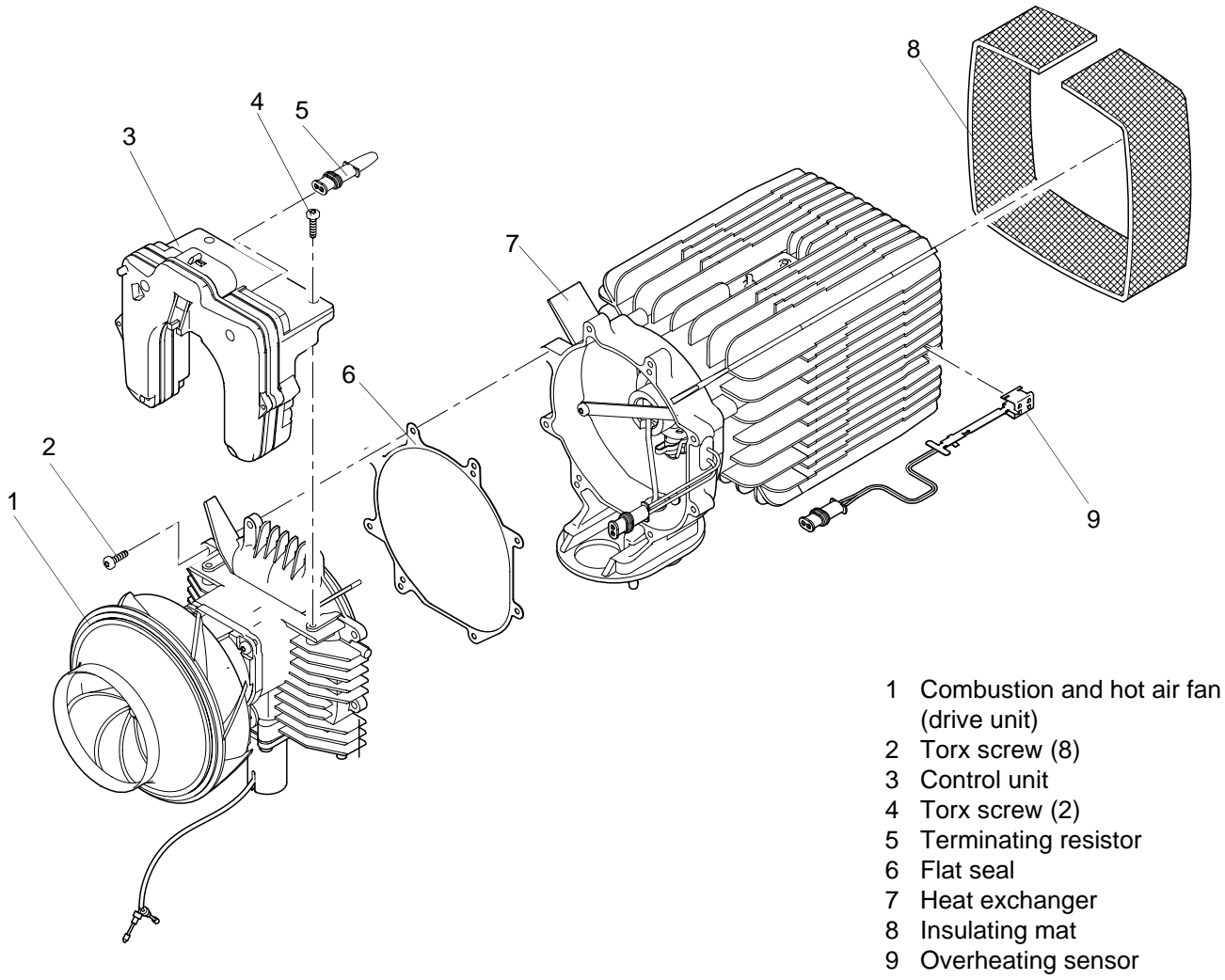

Detail A

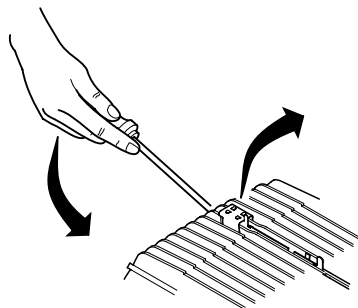

Fig. 902 Change the control unit, overheating sensor and the combustion and hot air blower (drive unit)

**9.2.6 Change the burner and the glow plug/
flame sensor****9.2.6.1 Removal**

1. Remove the heater (see 8.7.1.1).
2. Remove the casing parts (see 9.2.1).
3. Remove the control unit (see 9.2.3.1).
4. Remove the combustion and hot air blower (see 9.2.5.1).
5. Remove 2 screws (1, Fig. 903) and take off the retaining bar (2).
6. Press the grommet on the glow plug/flame sensor (8) inwards out of the heat exchanger casing (6).
7. Press the grommet on the burner's fuel line (3 or 7) inwards out of the heat exchanger casing (6).
8. Carefully pull the burner (3 or 7) out of the combustion pipe (4) and take the fuel supply out of the heat exchanger casing (6) by turning the burner.
9. Remove the retaining clip (9) and pull the glow plug/flame sensor (8) out of the burner (3 or 7).
10. Complete the work on stripped down components (see 9.1.1).

9.2.6.2 Installation

1. Insert the glow plug/flame sensor (8, Fig. 903) into the burner (3 or 7) (cable towards the opening for the cable grommet) and secure it with the retaining clip (9).
2. Insert the burner (3 or 7) into the heat exchanger (6) in the opposite direction and insert it into the combustion pipe (4).
3. Place the retaining bar (2) in its assembly position and secure it with 2 screws (1).
4. Tighten the screws to 4 ± 0.4 Nm.
5. Press the grommet on the fuel line into the heat exchanger (6).
6. Thread the cable for the glow plug/flame sensor (9) through the opening in the heat exchanger casing (6).
7. Press the grommet into the heat exchanger. Ensure that the glow plug cables do not form a loop in the heat exchanger.
8. Fit the combustion and hot air blower (see 9.2.5.2).
9. Fit the control unit (see 9.2.3.2).
10. Fit the casing parts (see 9.2.2).
11. Install the heater (see 8.7.1.2).

**9.2.7 Change the combustion pipe and the heat
exchanger****9.2.7.1 Removal**

1. Remove the heater (see 8.7.1.1).
2. Remove the casing parts (see 9.2.1).
3. Remove the control unit (see 9.2.3.1).
4. Remove the overheating sensor (see 9.2.4.1).
5. Remove the combustion and hot air blower (see 9.2.5.1).
6. Remove the burner (see 9.2.6.1).
7. Remove 2 screws (1, Fig. 903) and pull the combustion pipe (4) out of the heat exchanger (6).
8. Remove and discard the round sealing ring (5) from the heat exchanger (6).
9. Complete the work on stripped down components (see 9.1.1).

9.2.7.2 Installation

1. Fit a new round sealing ring (5, Fig. 903) into the heat exchanger (6).
2. Secure the combustion pipe (4) with 2 screws on opposite sides (1).
3. Tighten the screws to 4 ± 0.4 Nm.
4. Fit the burner (see 9.2.6.2).
5. Fit the combustion and hot air blower (see 9.2.5.2).
6. Fit the control unit (see 9.2.3.2).
7. Fit the overheating sensor (see 9.2.4.2).
8. Fit the casing parts (see 9.2.2).
9. Install the heater (see 8.7.1.2).

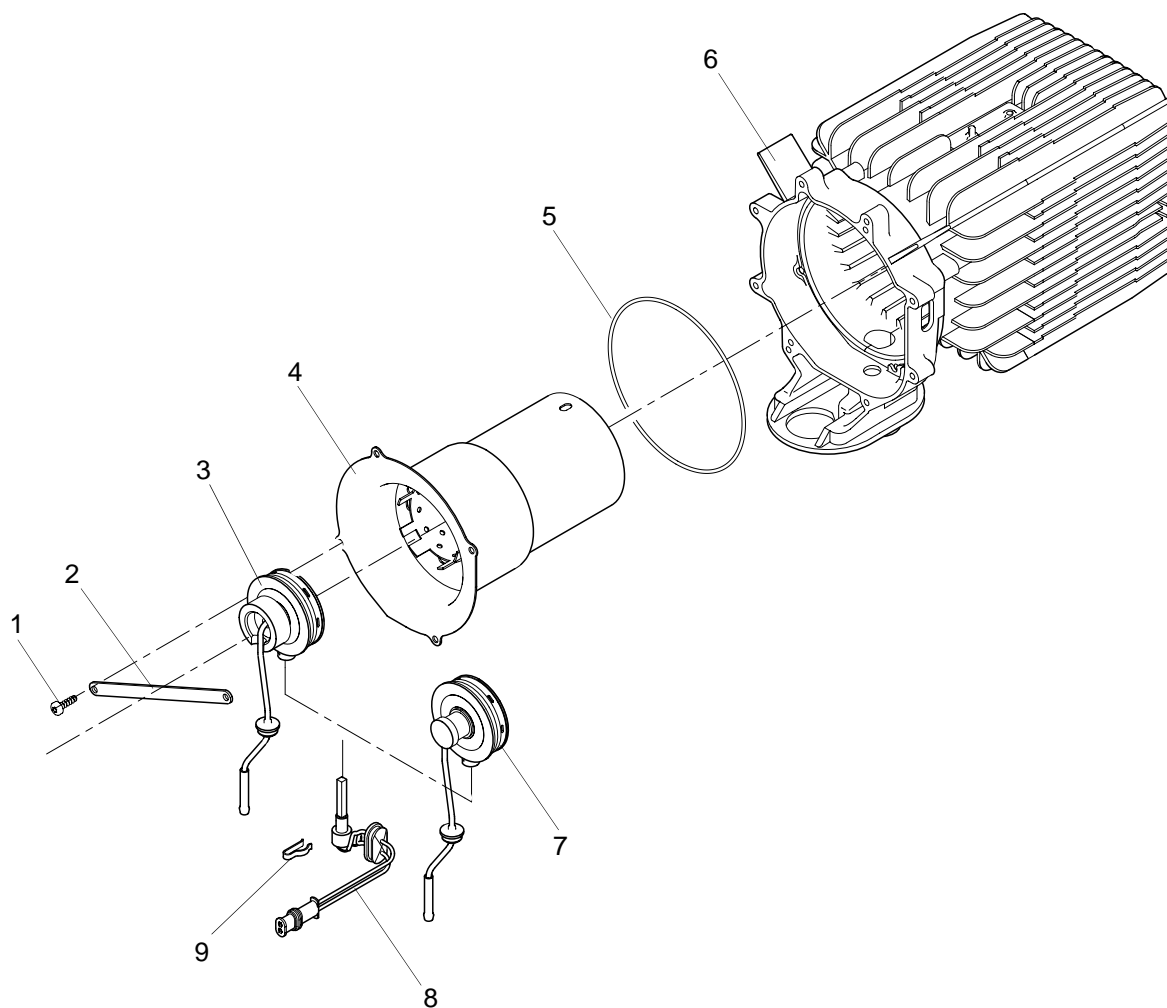

- 1 Torx screw (4)
- 2 Retaining bar
- 3 Diesel burner
- 4 Combustion pipe
- 5 Round sealing ring
- 6 Heat exchanger
- 7 Petrol burner
- 8 Glow plug / Flame monitor
- 9 Retaining clip

Fig. 903 Change the burner, glow plug/flame sensor, the combustion tube and the heat exchanger

10 Packaging, storage and shipping

10.1 General

If the heater or its components are sent to Webasto Thermosysteme GmbH for testing or repair, it must be cleaned and packed in such a way that it is protected against damage during handling, transport and storage.

An ambient temperature of +85 °C or - 40 °C must not be exceeded for storage.

Shipment address:

Webasto AG
Neubrandenburg Plant
Warranty Department
Speicherstraße 3/4
D-17033 Neubrandenburg

