

S4 - Top Hung Window



Outside view



Inside view

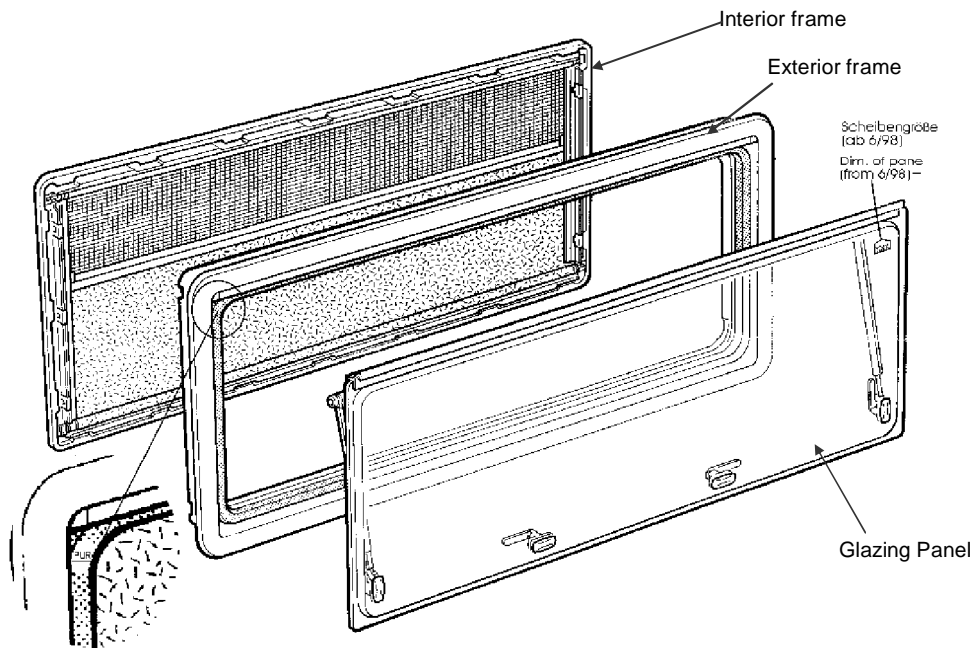

Exterior frame

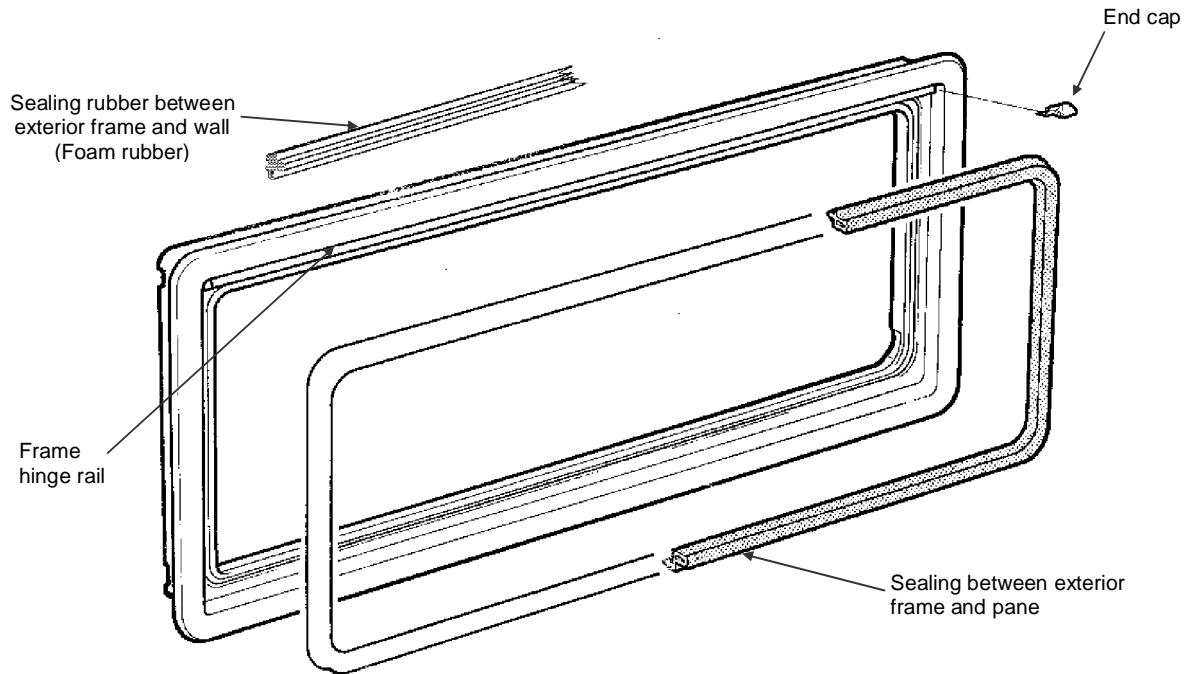

PROBLEM :

Replacement of the exterior frame
Replacement of the sealing rubber
Replacement of the end cap

Replacement of the exterior frame

For the dismantling of the exterior frame, first remove the caps of the interior frame and then loosen all screws of the interior frame.

Caution!: Before the screwed connections of the exterior frame are loosened, it must be ensured that the window is secured from outside against falling out.

Carefully remove the interior frame and exterior frame completely, beginning at a corner of the partition wall of vehicle. Before the insertion of the new exterior frame, the sealing surface of the wall section is to be cleaned. With the installation, a suitable caulking material must be employed. Permanently-plastic sealant mass (bead \varnothing 6-8mm) is applied all round in the corner of the frame to seal the exterior frame. From inside, the exterior and interior frames are screwed together with each other, where it is to be ensured that the screws are not tightened too much (max. tightening torque 3 Nm).

Replacement of the sealing rubber

Remove sealing rubber from the slot

Caution!: Bond at the corners and at the joint with superglue.



Remove adhesive residue with the aid of a small screwdriver. While inserting the new sealing rubber, it is to be ensured that the joint of the rubber seats centrally below. In order to stabilize the rubber, it is required to fix the corners and the joint with superglue.

Replacement of the end cap



If the end cap has broken-off, there is a possibility of replacing it. For this, it is necessary to disconnect the rear leg of the flush end cap. Bond front side and leg to the frame hinge with the aid of superglue.

Interior frame

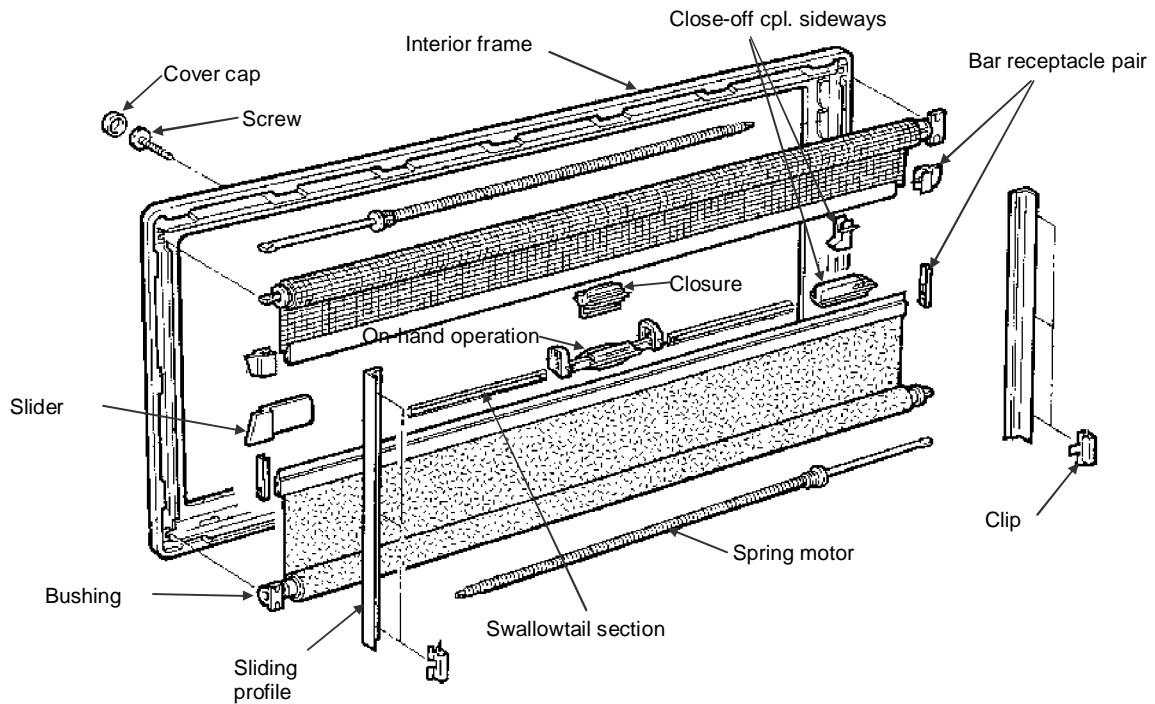

PROBLEM :

- Replacement of the complete interior frame
- Replacement of the fly protection window blind
- Replacement of the shade blind
- Replacement of the spring drive motor
- Replacement of the close-off
- Replacement of the side close-offs
- Replacement of the one-hand operation
- Replacement of the slider and swallowtail section

Replacement of the complete interior frame



Remove caps with the aid of an awl. Loosen recessed head screw and remove interior frame. Before the loosening the last screw, it is to be ensured that the exterior frames with windowpane cannot fall out.

Replacement of the fly protection window blind



Loosen spring drive motor from receptacle frame with the aid of pointed pliers.

Caution!: Spring is under stress. Danger of injury!



The window blind can then be removed by tilting the closure rod from the interior frame. The installation is implemented in reverse order, considering the clamping bar.

Clamping bar: Tube length in mm/100 +3= rotation of the spring drive motor shaft

Example: Tube length =1000mm 1000mm/100+3= 13 that is: 13 rotations clockwise

Replacement of the shade blind

Replacement is on principle similar to replacement of the fly protection window blind

Replacement of the spring drive motor



In order to replace the spring drive motor, the dismantling of the respective window blind is required (see replacement of the fly protection window blind). Widen the slotted tube with the aid of a screwdriver and remove the spring drive motor sideways. Installation is implemented in reverse order.

Replacement of the close-off

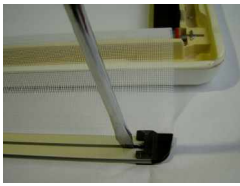

Dismantle interior frame as described under replacement of the complete interior frame. Take out the corresponding window blind from the guide by tilting the closure rod and, with the aid of a screwdriver, knock bar receptacle and close-off sideways from the closure rod. Mount new part in reverse order.

Replacement of the side close-offs



Above a window width of 1300 mm, side close-offs are installed that can be exchanged with replacement of the close-off.

Replacement of the one-hand operation

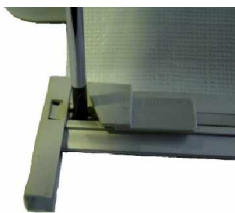

Dismantle interior frame as described under replacement of the complete interior frame. Remove the corresponding window blind by tilting the closure rod (see under replacement of the fly protection window blind). Knock out bar receptacles carefully sideways with the aid of a screwdriver and plastic hammer.



Through lifting the slider at the one-hand operation the swallowtail section....



... can be lifted out sideways together with the slider.



Knock out one-hand operation sideways with the aid of a plastic hammer from the dovetailed guide. It is absolutely necessary to secure the closure rod against side displacement during the knocking out. Assembly of the new parts is implemented in reverse order.

Replacement of the slider and swallowtail section

As described under replacement of the one-hand operation, procedure is similar to the replacement of the slider and swallowtail section.

Windowpane

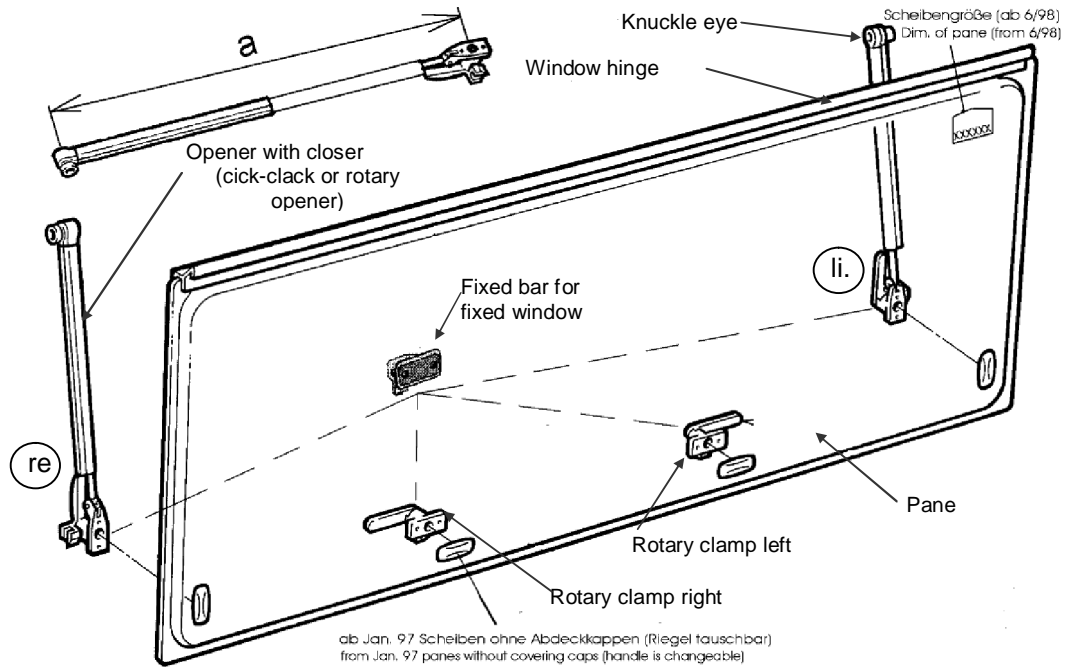

PROBLEM:

Windowpane replacement
Replacement of the opener
Replacement of the rotary clamp

Windowpane replacement



Loosen the fixing screws on the side articulated supports of the opener. Unlock pane on the lock.

Caution!: With opening the windowpane through 90° it releases itself from the frame hinge and falls out.

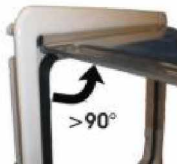

With fixing in a new acrylic pane, it must be ensured that the windowpane hinge is positioned properly in the frame hinge. With fixing the windowpane, the fitting angle must be $>90^\circ$, so that the windowpane hinge can be inserted into the frame hinge. Before closing, ensure freedom of movement in order to avoid possible damage in the hinge area. Then close window and fasten opener to the frame.

Replacement of the opener

In order to replace the opener, open window pane by approx. 45°. Then clip off the opener from the opener receptacle (rotary clamp). Dismantle openers at the articulated lug of the exterior frame. Mount the spare part in reverse order again

Replacement of the rotary clamp

Loosen rotary clamp at the fixing screws and install new part in reverse order.