



Diavia

VOLKSWAGEN CRAFTER 2500 TDI

*MOTORE "BJL" - MOTEUR "BJL"
"BJL" ENGINE - MOTOR "BJL" MOTOR "BJL"*

Montaggio compressore SP 15

Pose compresseur SP 15

SP 15 compressor installation

Einbau des Kompressors SP 15

Montaje compresor SP 15

Codice / Code: 7VW121 (A07VW121)

Istruzioni di montaggio

Instructions pour le montage

Fitting instructions

Einbauanleitungen

Instrucciones de montaje

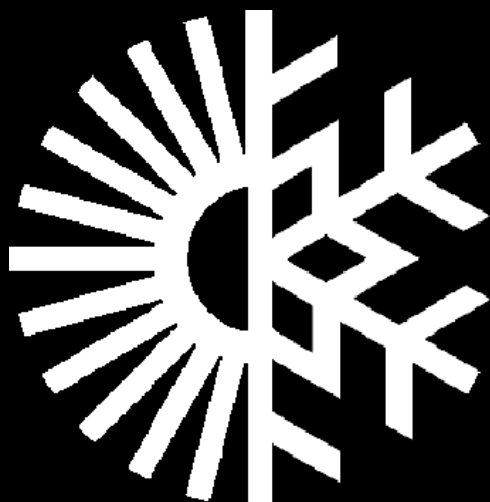

**DESCRIZIONE SIMBOLOGIA UTILIZZATA / DESCRIPTION DE LA SYMBOLOGIE UTILISÉE
DESCRIPTION OF SYMBOLS USED / BESCHREIBUNG DER VERWENDETEN SYMBOLIK
DESCRIPCIÓN DE LOS SIMBOLOS UTILIZADOS**

1A Riferimento a figura / Référence à la figure / See figure
In Bezug auf Abbildungen / Referencia a la figura

1- **1** Riferimento a componenti di fornitura / Référence aux composants de la fourniture
See supplied components / Bezug auf Gelieferte Einbauelemente
Referencia a los componentes de abastecimiento

1 Riferimento a posizione schema elettrico / Référence à la position du schéma électrique
See position in wiring diagram / In Bezug auf Position im Schaltschema /
Referencia a la posición del esquema eléctrico



- Lubrificare tutti i raccordi e gli O.R. con il nuovo olio refrigerante prima di collegarli

- Graisser tous les raccords et les O.R. avec le nouveau huile réfrigérant avant de les raccorder

-Lubricate all fittings and O-rings with new refrigerant oil before connecting them

- Alle Verbindungsstücke und OR-Ringe vor deren Verbindung mit dem neuen Kühlmittelöl ölen

- Lubrificar todos los empalmes y los O.R. con el nuevo aceite refrigerante antes de conectarlos

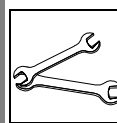

- Per avvitare a fondo o allentare i raccordi tubi gas usare due chiavi per bilanciare coppia di torsione

- Pour visser à fond ou desserrer les raccords des tuyaux gaz, utiliser le deux clés pour équilibrer le couple de torsion

- When tightening or loosening the fittings of the gas pipes, use two wrenches to equalize the torsion couple

- Um die Verbindungsstücke der Kältemittelschläuche gleichmäßig festzuschrauben oder zu lockern, zwei Schlüssel für das Verschraubungspaar verwenden

- Para enrosacar a fondo o aflojar los empalmes tubos gas se deben usar dos llaves para balancear el par de torsión



- Tagliare con utensile appropriato al materiale

- Couper à l'aide d'outil approprié

- Cut with a device suitable for the material

- Mit dem Material entsprechendem Werkzeug schneiden

- Cortar con herramienta apropiada al material

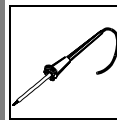

- Stagnare

- Étamer

- Tin

- Verzinnen

- Estañar



- Spianare

- Nivelar

- Flatten out

- Richten

- Nivelar

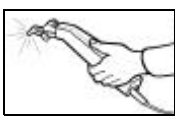

- Tagliare con utensile a lama calda

- Couper à l'aide d'un outil à lame chaude

- Cut using the tool with heated blade.

- Mit Schweißmesserwerkzeug schneiden

- Cortar con útil a hoja caliente

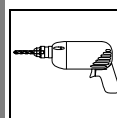

- Forare

- Percer

- To drill

- Durchbohren

- Taladrar

Pos.	ITALIANO	FRANÇAIS	ENGLISH	DEUTSCH	ESPAÑOL
1	Compressore	Compresseur	Compressor	Kompressor	Compresor
1.1	Cablaggio PACKARD per compressore	Câblage PACKARD pour compresseur	PACKARD wiring for compressor	PACKARD Kabelstrang für Kompressor	Cableado PACKARD para compresor
2	Piastra supporto compressore	Plaque support compresseur	Compressor support plate	Kompressorträger	Placa soporte compresor
3	Puleggia galoppino	Poulie de renvoi	Idle pulley	Leitrollenriemenscheibe	Polea directriz
4	Cinghia	Courroie	Belt	Riemen	Correa
5	Bulloneria	Boulonnerie	Nuts and bolts	Schraubensatz	Tornillería

**MONTAGGIO COMPRESSORE / POSE DU COMPRESSEUR / COMPRESSOR FITTING
KOMPRESSOREINBAU / MONTAJE COMPRESOR**

MATERIALE FORNITO / MATERIEL FOURNI / SUPPLIED MATERIAL / GELIEFERTES MATERIAL / MATERIAL ABASTECIDO



7VW121 (A07VW121)

1A

Componente d'acquisto a cura dell'installatore, non inserito nel KIT A07VW121

Composant à acheter par l'installateur, non fourni dans le Kit A07VW121

★ Component to be purchased by the installer. Not included in KIT A07VW121.

*Nicht im Einbausatz A07VW121 enthaltene und vom Einbauer separat zu kaufende Einbauteile
Componente de compra a cargo del instalador, no incluido en el Kit A07VW121*

Pos.	Descrizione / Description / Description Beschreibung / Descripción	Codice / Code Kode / Código
1★	Compressore	015203/1
1.1	Cablaggio PACKARD per compressore	028839/0
2	Piastra supporto compressore	0011243/0
3	Puleggia galoppino	004084/0
4	Cinghia 6K x 2585	013689/0
5	Bulloneria	037VW120

**OPERAZIONI PRELIMINARI / OPERATIONS PRELIMINAIRES / PRELIMINARY OPERATIONS
VORBEREITUNGSARBEITEN / OPERACIONES PRELIMINARES**

- (I)**
- Scollegare la batteria.
 - Smontare la grembialina inferiore di protezione motore.

- (F)**
- Déconnecter la batterie.
 - Déposer l'écran inférieur de le moteur.

- (GB)**
- Disconnect the battery.
 - Remove the driving lower screen.

- (D)**
- Die Batterie lösen.
 - Die zum Schutz der Motorriemenscheibe dienende untere Abdeckung ausbauen.

- (E)**
- Desconectar la batería.
 - Desmontar la protección inferior del motor.

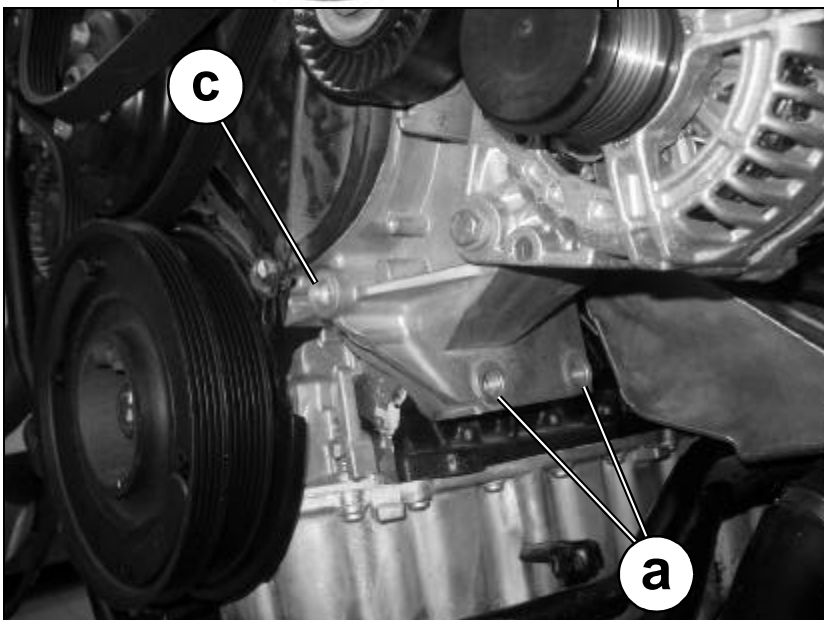
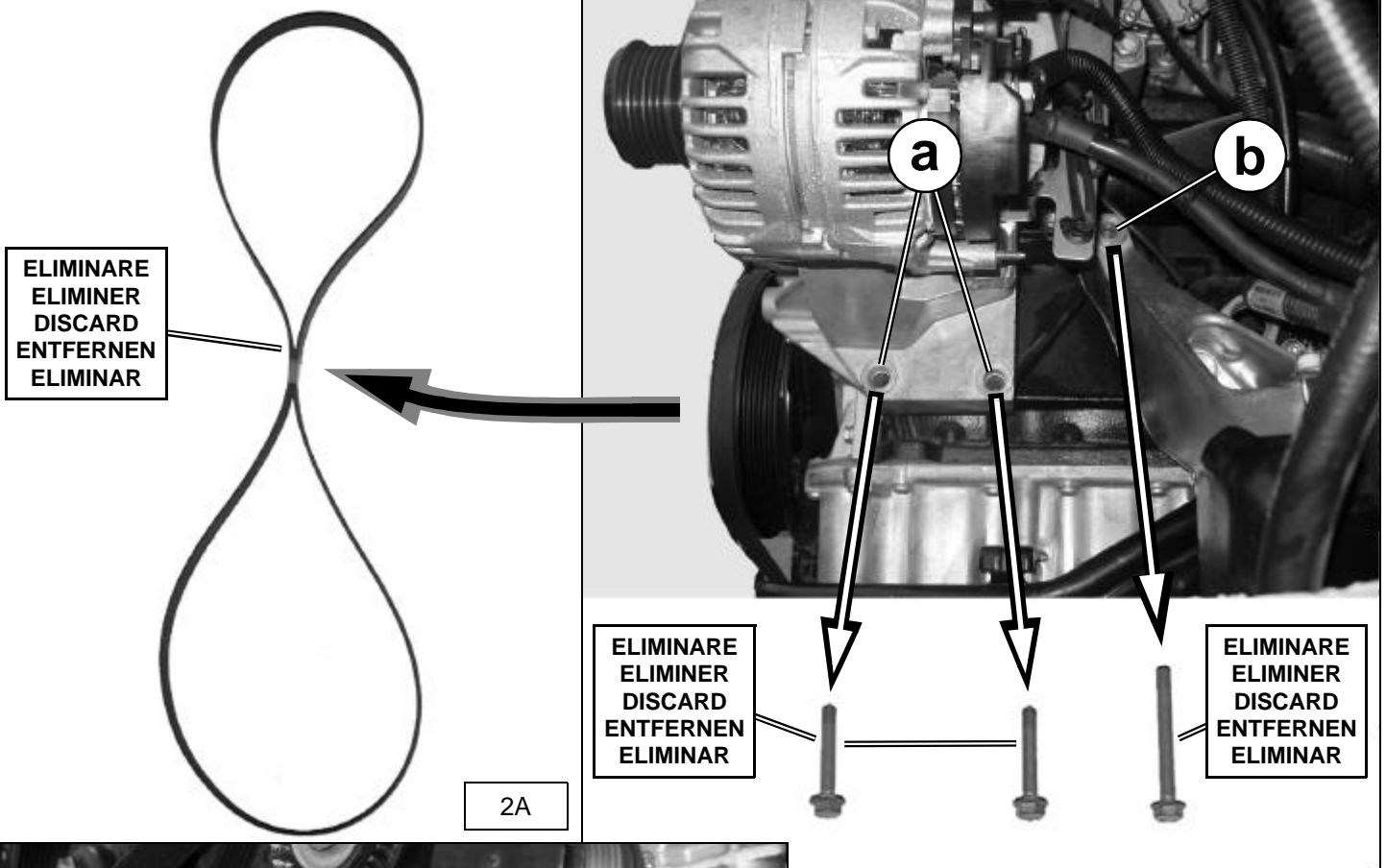

**PUNTI DI FISSAGGIO
POINTS DE FIXATION
SECURING POINTS
BEFESTIGUNGSPUNKTE
PUNTOS DE FIJACION**



SBLOCCARE
DÉBLOQUER
RELEASE
LOCKERN
DESBLOQUEAR

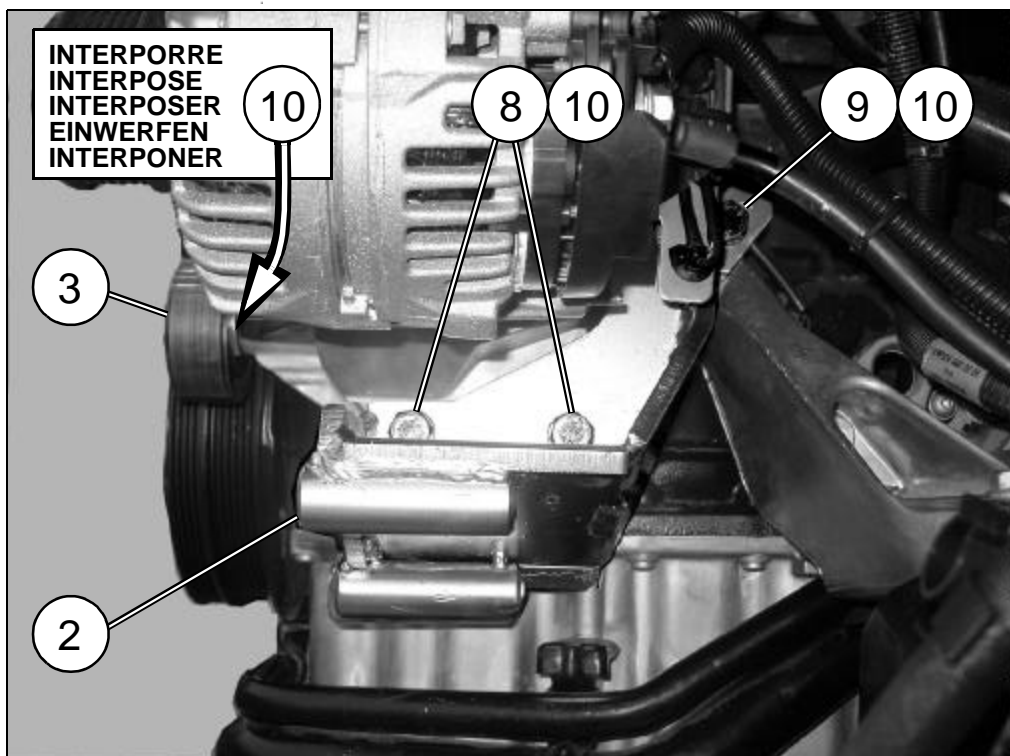

INTERPORRE
INTERPOSE
INTERPOSER
EINWERFEN
INTERPONER

3A

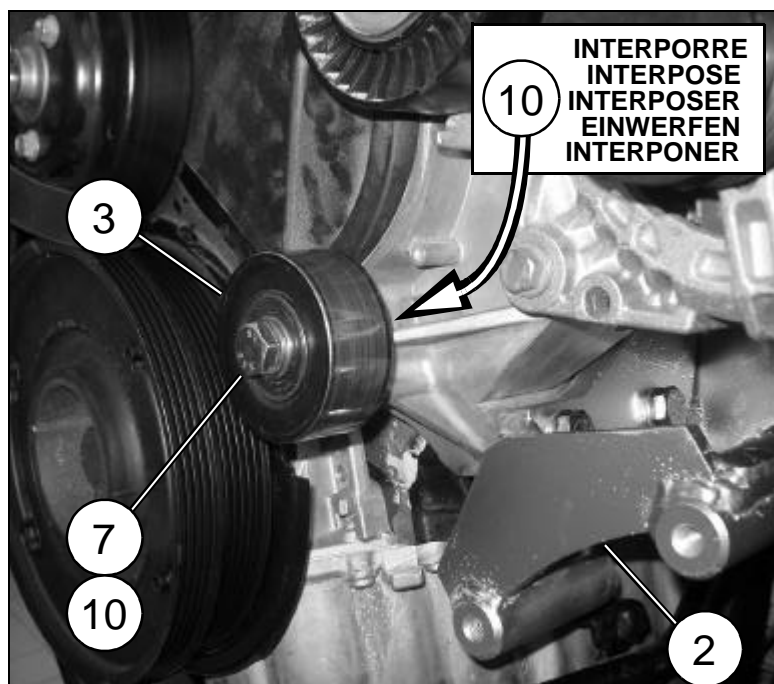

INTERPORRE
INTERPOSE
INTERPOSER
EINWERFEN
INTERPONER

BULLONERIA DA UTILIZZARE BOULONNERIE A UTILISER NUTS AND BOLTS TO BE USED ZU BENUTZENDER SCHRAUBENSATZ TORNILLERIA A UTILIZAR		
Pos.	Tipologia / Typologie Typology / Tipologie Tipologia	Descrizione / Description Description / Beschreibung Descripción
7		M10x50
8		M10x75
9		M10x100
10		φ 10

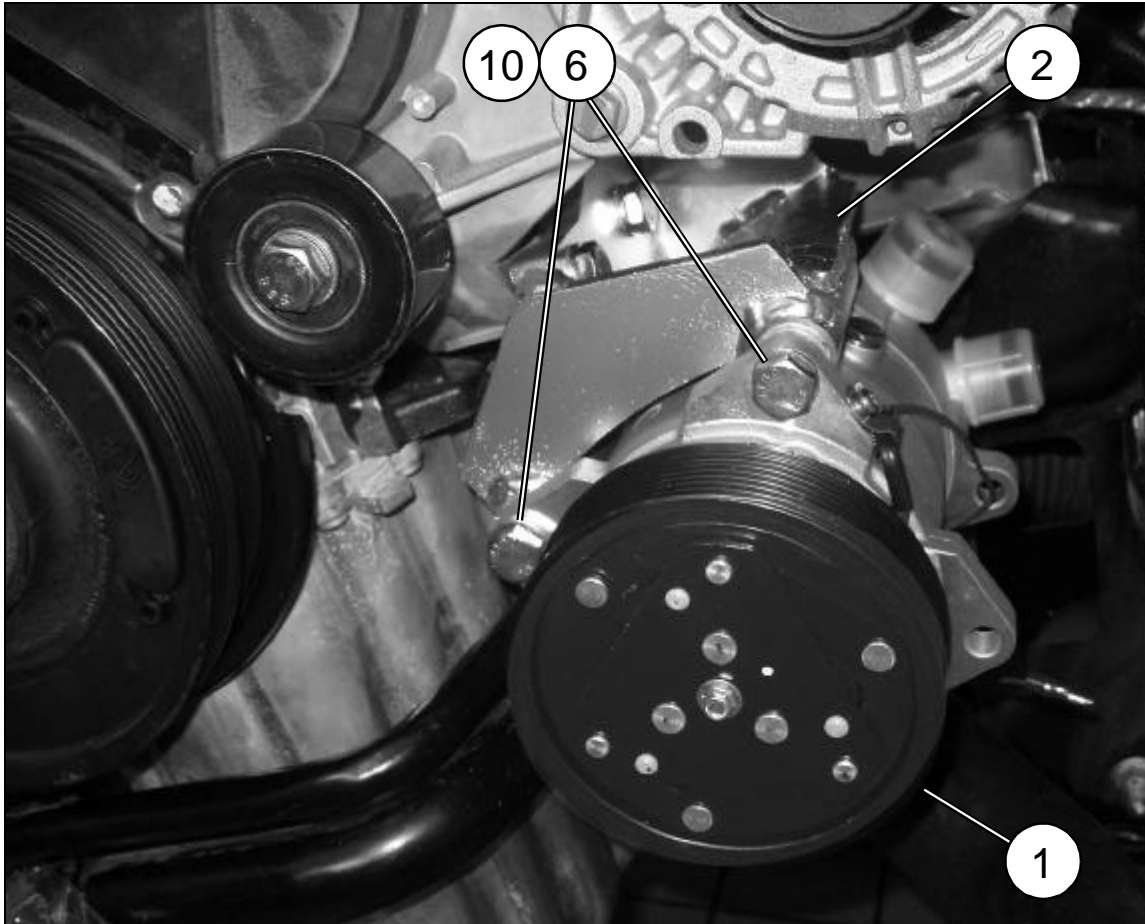

4A

BULLONERIA DA UTILIZZARE BOULONNERIE A UTILISER NUTS AND BOLTS TO BE USED ZU BENUTZENDER SCHRAUBENSATZ TORNILLERIA A UTILIZAR		
Pos.	Tipologia / Typologie Typology / Tipologie Tipologia	Descrizione / Description Description / Beschreibung Descripción
6		M10x30
10		φ 10

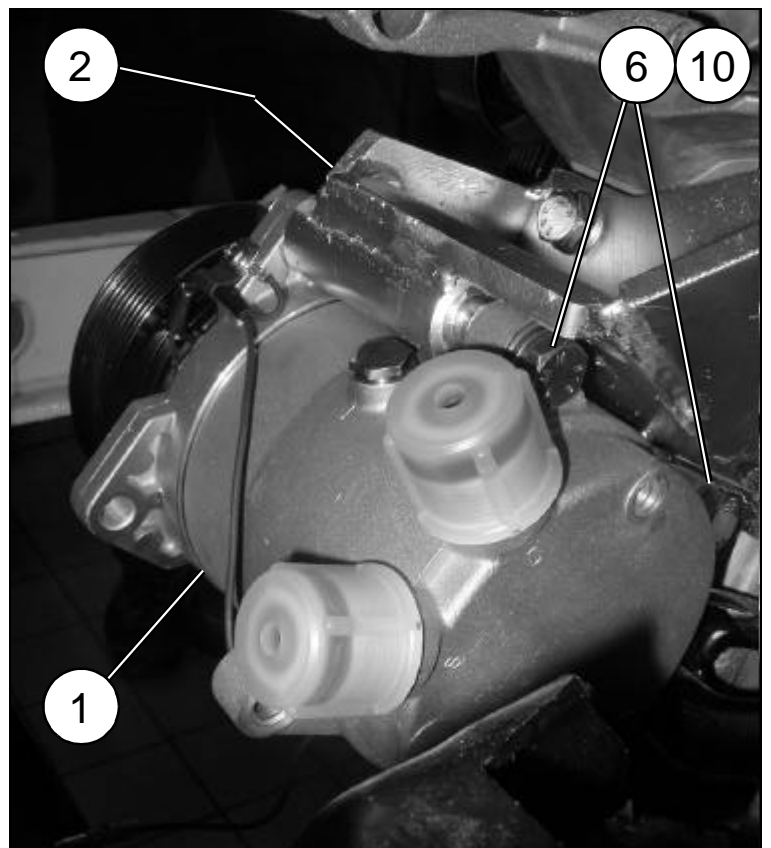

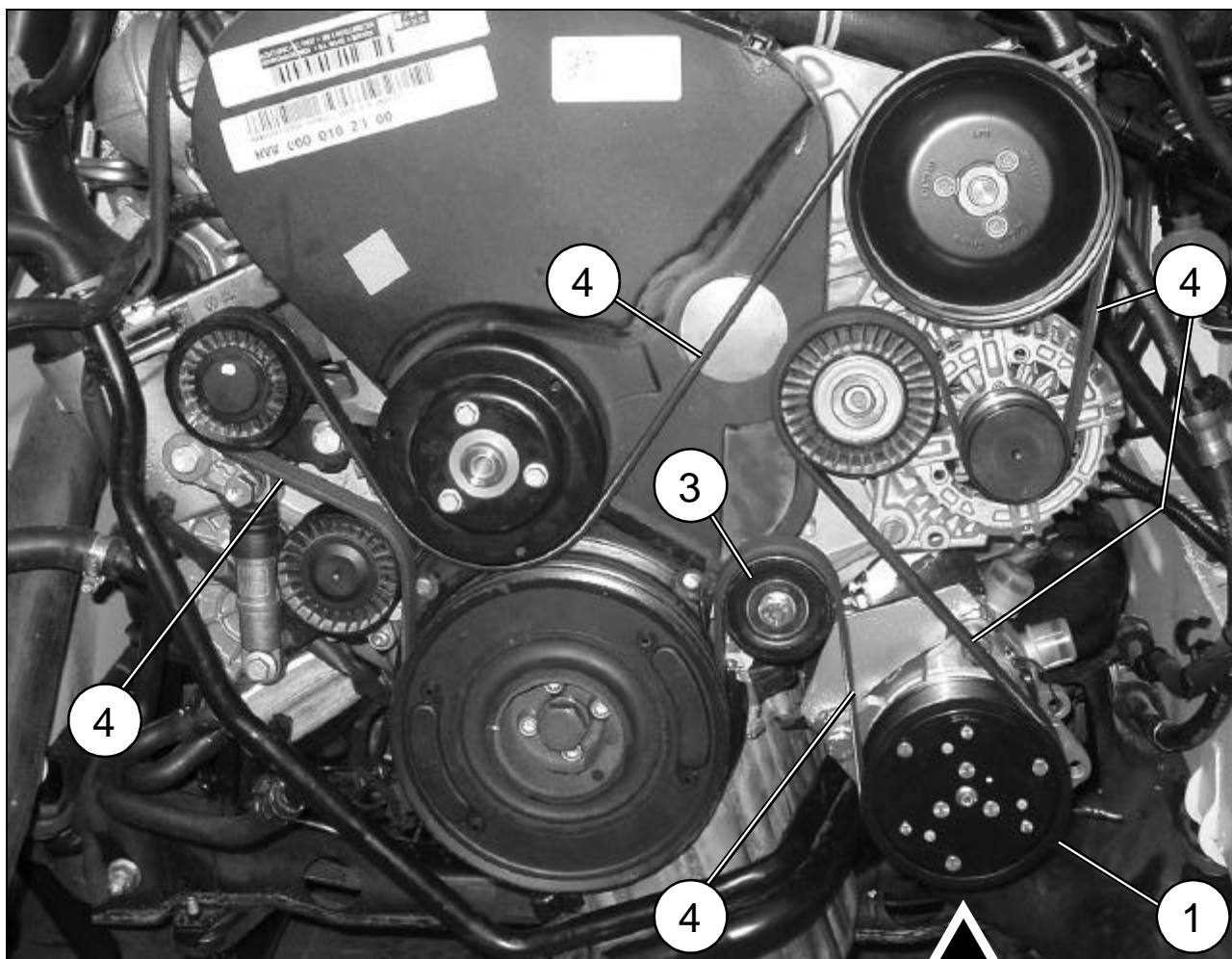

5A

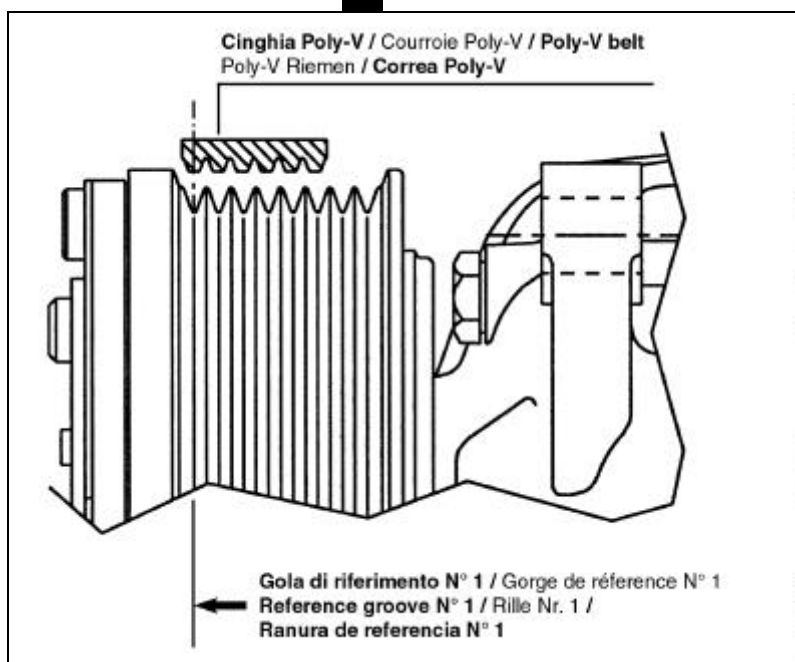

(I)
DELPHI ITALIA mira ad un costante miglioramento dei propri prodotti. La Casa si riserva il diritto di apportare in qualunque momento e senza preavviso modifiche ai modelli e ai componenti descritti in questa pubblicazione per ragioni di natura tecnica o commerciale. Per ulteriori informazioni rivolgersi al servizio assistenza DELPHI.

(F)
DELPHI ITALIA vise à une amélioration constante des ces produits. La maison se réserve le droit d'apporter, à tout moment et sans préavis, des modifications aux modèles et aux composants décrits dans cette publication pour des raisons d'ordre technique ou commerciale. Pour d'ultérieures informations s'adresser au service d'assistance DELPHI.

(GB)
DELPHI ITALIA focuses on constant upgrading of its products. The Manufacturer reserves the right to modify the models and components described in the present publication at any time for technical or commercial reasons and without prior notice. For further information, contact DELPHI technical services.

(D)
DELPHI ITALIA ist stets bestrebt die eigenen Produkte zu verbessern. Die Herstellerfirma behält sich das Recht vor, aus technischen oder Verkaufsgründen, zu jeder Zeit und ohne vorherige Ankündigung, Abänderungen an den Modellen und den in dieser Veröffentlichung beschriebenen Einbauteile vorzunehmen. Für weitere Informationen bitten wir Sie, sich an unseren DELPHI Kundendienst zu wenden.

(E)
DELPHI ITALIA aspira a un constante mejoramiento de su producción. La Fábrica se reserva el derecho de aportar en cualquier momento y sin preaviso modificaciones a los modelos y los componentes descritos en esta publicación por razones técnicas o comerciales. Para ultiores informaciones dirigirse al servicio asistencia DELPHI.

VENDITA E SERVIZIO
VENTE ET SERVICE

VERKAUF UND SERVICE
SALE AND SERVICE

DELPHI ITALIA AUTOMOTIVE SYSTEMS S.r.l.
Stabilimento Molinella

Via Nobili, 2 40062 Molinella (Bologna)-Italy

Telefono (0039) 051.6906111

Fax (0039) 051.6906287

Email: diavia.service@delphi.com

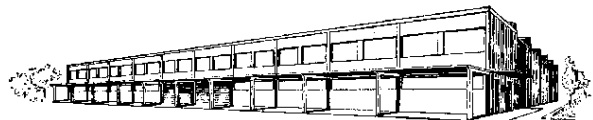

MOD. SCHVW286

XI / '06
(2006)

Questa pubblicazione è stata curata da DELPHI ITALIA-Diavia
Ufficio Fitting Instructions - Stabilimento Molinella

This publication has been edited by DELPHI ITALIA-Diavia
Fitting Instructions Office - Factory Molinella